

# **Hardin County Water District No. 2**



## **STANDARDS, SPECIFICATIONS AND DETAILS FOR WATER MAIN DESIGN & CONSTRUCTION**

October 2007

## Table of Contents

<b>I.</b>	<b>Purpose</b>	<b>pg. 3</b>
<b>II.</b>	<b>General Conditions</b>	<b>pg. 4 - 14</b>
<b>III.</b>	<b>Technical Specifications</b>	<b>pg. 15 - 60</b>
<b>IV.</b>	<b>Standard Drawings and Details</b>	<b>pg. 61 - 84</b>
<b>V.</b>	<b>Design Standards</b>	<b>pg. 85 - 86</b>
<b>VI.</b>	<b>Approved Material List For Water Main Construction</b>	<b>pg. 87 - 88</b>



## I. Purpose



### **Hardin County Water District No. 2 Standards, Specifications & Details**

**The purpose of these Standards, Specifications & Details is to provide standards for design and construction of water extensions constructed through Developer Agreements. These Standards shall be utilized by the Developer's Engineer and Contractor.**

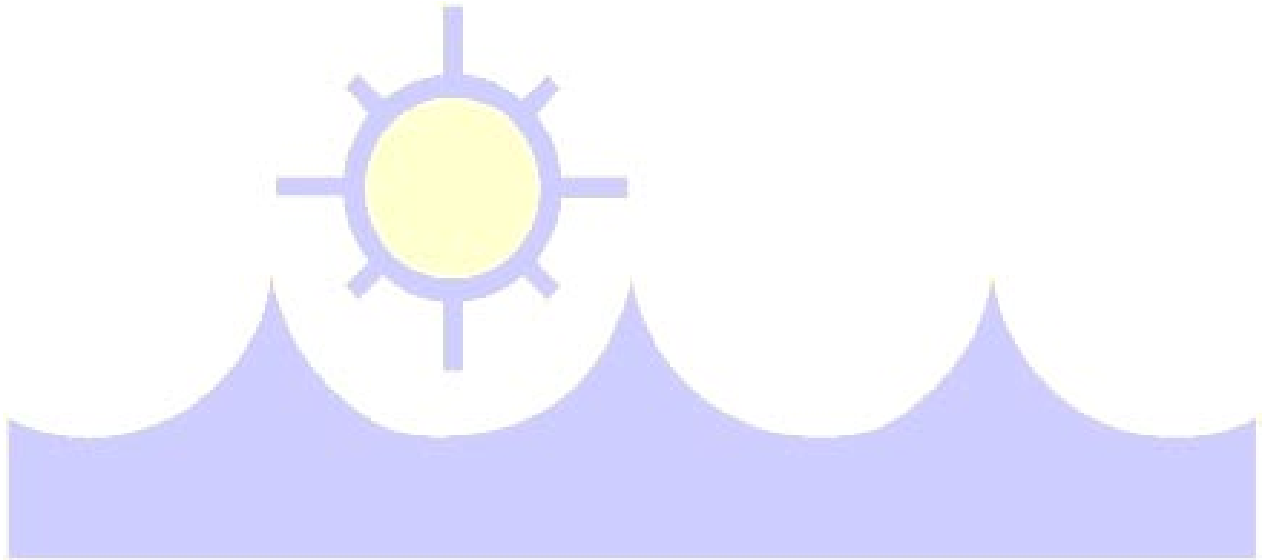

## II. GENERAL CONDITIONS

### 1. DEFINITIONS

1.1 CONTRACT DOCUMENTS - The Contract documents consist of the DEVELOPER AGREEMENT, the DRAWINGS, and SPECIFICATIONS.

1.2 CONTRACTOR - The person, firms, or corporation with whom the DEVELOPER has executed the Construction Contract.

1.3 DRAWINGS - The parts of the CONTRACT DOCUMENTS which show the characteristics and scope of the WORK to be performed and which have been prepared or approved by the ENGINEER.

1.4 ENGINEER - The person, firm, or corporation under contract with the DEVELOPER to prepare DRAWINGS.

1.5 OWNER - HCWD#2 for whom the WORK is to be performed.

1.6 PROJECT - The undertaking to be performed as provided in the CONTRACT DOCUMENTS.

1.7 INSPECTOR - The authorized representative of the OWNER who is assigned to the PROJECT site or any part thereof.

1.8 SHOP DRAWINGS - All drawings, diagrams, illustration, brochures, schedules and other data which are prepared by the CONTRACTOR, a SUBCONTRACTOR, manufacturer, SUPPLIER or distributor, which illustrate how specific portions of the WORK shall be fabricated or installed.

1.9 SPECIFICATIONS - A part of the CONTRACT DOCUMENTS, HCWD#2 Standards, Specifications and Details for water main and Construction.

1.10 SUBCONTRACTOR - An individual, firm, or corporation having a direct contract with CONTRACTOR or with any other SUBCONTRACTOR for the performance of a part of the WORK at the site.

1.11 SUBSTANTIAL COMPLETION - That date certified by the ENGINEER when the construction of the PROJECT or a specified part thereof is sufficiently completed, in accordance with the CONTRACT DOCUMENTS, so that the PROJECT or specified part can be utilized for the purposes for which it is intended.

1.12 SUPPLIER - Any person or organization who supplies material or equipment for the WORK, including that fabricated to a special design, but who does not perform labor at the site.

1.13 **WORK** - All labor necessary to produce the construction required by the **CONTRACT DOCUMENTS**, and all materials and equipment incorporated or to be incorporated in the **PROJECT**.

1.14 **WRITTEN NOTICE** - Any notice to any party of the Agreement relative to any part of this Agreement in writing and considered delivered and the service thereof completed, when posted by certified or registered mail to the said party at their last given address, or delivered in person to said party or their authorized representative on the **WORK**.

## **2. ADDITIONAL INSTRUCTIONS AND DETAIL DRAWINGS**

2.1 The **CONTRACTOR** may be furnished additional instructions and detail drawings, by the **ENGINEER**, as necessary to carry out the **WORK** required by the **CONTRACT DOCUMENTS**.

2.2 The additional drawings and instructions thus supplied will become a part of the **CONTRACT DOCUMENTS**. The **CONTRACTOR** shall carry out the **WORK** in accordance with the additional detail drawings and instructions.

## **3. DRAWINGS AND SPECIFICATIONS**

3.1 The intent of the **DRAWINGS** and **SPECIFICATIONS** is that the **CONTRACTOR** shall furnish all labor, materials, tools, equipment, and transportation necessary for the proper execution of the **WORK** in accordance with the **CONTRACT DOCUMENTS** and all incidental work necessary to complete the **PROJECT** in an acceptable manner, ready for use, occupancy or operation by the **OWNER**.

3.2 In case of conflict between the **DRAWINGS** and **SPECIFICATIONS**, the **SPECIFICATIONS** shall govern. Figure dimensions on **DRAWINGS** shall govern over general **DRAWINGS**.

3.3 Any discrepancies found between the **DRAWINGS** and **SPECIFICATIONS** and site conditions or any inconsistencies or ambiguities in the **DRAWINGS** or **SPECIFICATIONS** shall be immediately reported to the **ENGINEER** and **OWNER**, in writing, or shall promptly correct such inconsistencies or ambiguities in writing. **WORK** done by the **CONTRACTOR** after discovery of such discrepancies, inconsistencies or ambiguities shall be done at the **CONTRACTOR'S** risk.

## **4. SHOP DRAWINGS**

4.1 The **CONTRACTOR** shall provide **SHOP DRAWINGS** as may be necessary for the prosecution of the **WORK** as required by the **CONTRACT DOCUMENTS**. The **ENGINEER & OWNER** shall promptly review all **SHOP DRAWINGS**. The **ENGINEER'S** and **OWNERS** approval of any **SHOP DRAWING** shall not release the **CONTRACTOR** from responsibility for deviations from the **CONTRACT DOCUMENTS**. The approval of any **SHOP DRAWING** which substantially deviates from the requirement of the **CONTRACT DOCUMENTS** shall be evidenced by a **CHANGE ORDER**.

4.2 When submitted for the ENGINEER'S and OWNER'S review, SHOP DRAWINGS shall bear the CONTRACTOR'S certification that he has reviewed, checked and approved the SHOP DRAWINGS and that they are in conformance with the requirements of the CONTRACT DOCUMENTS.

4.3 Portions of the WORK requiring a SHOP DRAWING or sample submission shall not begin until the SHOP DRAWING or submission has been approved by the ENGINEER & OWNER. A copy of each approved SHOP DRAWING and each approved sample shall be kept in good order by the CONTRACTOR at the site and shall be available to the ENGINEER & OWNER.

## **5. MATERIALS, SERVICES AND FACILITIES**

5.1 It is understood that, except as otherwise specifically stated in the CONTRACT DOCUMENTS, the CONTRACTOR shall provide and pay for all materials, labor, tools, equipment, water, light, power, transportation, supervision, temporary construction of any nature, and all other services and facilities of any nature whatsoever necessary to execute, complete, and deliver the WORK.

5.2 Materials and equipment shall be so stored as to insure the preservation of their quality and fitness for the WORK. Stored materials and equipment to be incorporated in the WORK shall be located so as to facilitate prompt inspection.

5.3 Manufactured articles, materials, and equipment shall be applied, installed, connected, erected, used, cleaned and conditioned as directed by the manufacturer.

5.4 Materials, supplies, and equipment shall be in accordance with samples submitted by the CONTRACTOR and approved by the ENGINEER.

5.5 Materials, supplies, or equipment to be incorporated into the WORK shall not be purchased by the CONTRACTOR or the SUBCONTRACTOR subject to a chattel mortgage or under a conditional sale contract or other agreement by which an interest is retained by the seller.

## **6. INSPECTION AND TESTING**

6.1 All materials and equipment used in the construction of the PROJECT shall be subject to adequate inspection and testing in accordance with generally accepted standards, as required and defined in the CONTRACT DOCUMENTS.

6.2 The OWNER shall provide all inspection and testing services not required by the CONTRACT DOCUMENTS.

6.3 The CONTRACTOR shall provide at the CONTRACTOR'S expense the testing and inspection services required by the CONTRACT DOCUMENTS.

#### 6.4 AUTHORITY AND DUTIES OF INSPECTORS

a) Inspectors shall be authorized to inspect all work done and all material furnished. Such inspection may extend to all or any part of the work and to the preparation, fabrication or manufacture of the materials to be used. The INSPECTOR is not authorized to revoke, alter or waive any requirements of the CONTRACT, nor is he authorized to approve or accept any portion of the completed project. He is authorized to call the attention of the CONTRACTOR to any failure of the work or materials to conform to the Specifications and Contract. He shall have the authority to reject materials or suspend the work until any questions at issue can be referred to and decided by the OWNER. Inspectors shall perform their duties at such times and in such manner as will not unnecessarily impede progress under the contract.

b) The Inspector shall in no case act as foremen or perform other duties for the Contractor, nor interfere with the management of the work by the CONTRACTOR. Any advice which the INSPECTOR may give the CONTRACTOR shall not be construed as binding the OWNER in any way, or releasing the CONTRACTOR from fulfilling all of the terms of the CONTRACT, or complying with these regulations or other applicable laws.

c) Where there is disagreement between the CONTRACTOR (or his representative) and the INSPECTOR, such as , refusal by the Contractor to use properly approved materials; for performing work not in compliance with DRAWINGS and SPECIFICATIONS; and/or refusing to suspend work until problems at issue can be referred to and decided by the OWNER, the Inspector will immediately notify the Owner as to the issue of disagreement and if the CONTRACTOR still refuses to make corrections, comply or suspend work, the OWNER will prepare and deliver in writing to the CONTRACTOR, by mail or otherwise, a written order suspending the work and explaining the reason for such shutdown. As soon as the INSPECTOR is advised of the delivery of the shutdown order, the INSPECTOR shall immediately leave the site of the work and any work performed during the INSPECTOR'S absence will not be accepted.

#### 7. SUBSTITUTIONS

7.1 Whenever a material, article, or piece of equipment is identified on the DRAWINGS or SPECIFICATIONS by reference to brand name or catalogue numbers, it shall be understood that this is referenced for the purpose of defining the performance or other salient requirements and that other products of equal capacities, quality and function shall be considered.

The CONTRACTOR may recommend the substitution of a material, article, or piece of equipment of equal substance and function for those referred to in the CONTRACT DOCUMENTS by reference to brand name or catalogue number, and if, in the opinion of the ENGINEER & OWNER, such material, article, or piece of equipment is of equal substance and function to that specified, the ENGINEER and OWNER may approve its substitution and use by the CONTRACTOR. Any cost differential shall be deductible from the CONTRACT PRICE and the CONTRACT DOCUMENTS shall be appropriately modified by CHANGE ORDER. The CONTRACTOR warrants that if substitutes are approved, no major changes in the function or general design of the PROJECT will result. Incidental changes or extra component parts required to accommodate the substitute will be made by the CONTRACTOR without a change in the CONTRACT PRICE or CONTRACT TIME.

## **8. PATENTS**

8.1 The CONTRACTOR shall pay all applicable royalties and license fees, and shall defend all suits or claims for infringement of any patent rights and save the OWNER harmless from loss on account thereof, except that the OWNER shall be responsible for any such loss when particular process, design, or product of a particular manufacturer or manufacturers is specified, however, if the CONTRACTOR has reason to believe that the design, process or product specified is an infringement of a patent, the CONTRACTOR shall be responsible for such loss unless the CONTRACTOR promptly gives such information to the ENGINEER.

## **9. SURVEYS, PERMITS, REGULATIONS**

9.1 The DEVELOPER shall furnish all boundary surveys and establish all base lines for locating the principal component parts of the WORK together with a suitable number of bench marks adjacent to the WORK as shown in the CONTRACT DOCUMENTS. From the information provide by the DEVELOPER, unless otherwise specified in the CONTRACT DOCUMENTS, the CONTRACTOR shall develop and make all detail surveys needed for construction such as slope stakes, batter boards, stakes for pipe locations and other working points, lines, elevations and cut sheets.

9.2 The CONTRACTOR shall carefully preserve bench marks, reference points and stakes and, in case of willful or careless destruction, shall be charged with the resulting expense and shall be responsible for any mistake that may be caused by their unnecessary loss or disturbance.

9.3 Permits and licenses of a temporary nature necessary for the prosecution of the WORK shall be secured and paid for by the CONTRACTOR unless otherwise stated in the SUPPLEMENTAL GENERAL CONDITIONS. Permits, licenses and easements for permanent structures or permanent changes in existing facilities shall be secured and paid for by the DEVELOPER, unless otherwise specified. The CONTRACTOR shall give all notices and comply with all laws, ordinances, rules and regulations bearing on the conduct of the WORK as drawn and specified. If the CONTRACTOR observes that the CONTRACT DOCUMENTS are at variance therewith, the CONTRACTOR shall promptly notify the ENGINEER in writing, and any necessary changes shall be adjusted as provided in Section 13, CHANGES IN THE WORK.

## **10. PROTECTION OF WORK, PROPERTY, AND PERSONS**

10.1 The CONTRACTOR will be responsible for initiating, maintaining and supervising all safety precautions and programs in connection with the WORK. The CONTRACTOR will take all necessary precautions for the safety of , will provide the necessary precautions for the safety of, and will provide the necessary protection to prevent damage, injury or loss to all employees on the WORK and other persons who may be affected thereby, all the WORK and all materials or equipment to be incorporated therein, whether in storage on or off the site, and other property at the site or adjacent thereto, including trees, shrubs, lawns, walks, pavements, roadways, structures and utilities not designated for the removal, relocation or replacement in the course of construction.



10.2 The CONTRACTOR will comply with all applicable laws, ordinances, rules, regulations and orders of any public body having jurisdiction. The CONTRACTOR will erect and maintain, as required by the conditions and progress of the WORK, all necessary safeguards for safety and protection. The CONTRACTOR will notify owners of adjacent utilities when prosecution of the WORK may affect them. The CONTRACTOR will remedy all damage, injury or loss to any property caused directly or indirectly, in whole or part, by the CONTRACTOR, any SUBCONTRACTOR or anyone directly or indirectly employed by any of them or anyone directly or indirectly employed by any of them or anyone of whose acts any of them be liable, except damage or loss attributable to the fault of the CONTRACT DOCUMENTS or to the acts or omissions of the OWNER, of the ENGINEER or anyone employed by either of them or anyone for whose acts either of them may be liable, and not attributable, directly or indirectly, in whole or in part, to the fault or negligence of the CONTRACTOR.

10.3 In emergencies affecting the safety of persons or the WORK or property at the site or adjacent thereto, the CONTRACTOR, without special instruction or authorization from the ENGINEER or OWNER, shall act to prevent threatened damage, injury or loss. The CONTRACTOR will give the ENGINEER and OWNER prompt WRITTEN NOTICE of any significant changes in the WORK or deviations from the CONTRACT DOCUMENTS caused thereby, and a CHANGE ORDER shall thereupon be issued covering the changes and deviations involved.

## **11. SUPERVISION BY CONTRACTOR**

11.1 The CONTRACTOR will supervise and direct the WORK. He will be solely responsible for the means, methods, techniques, sequences and procedures of construction. The CONTRACTOR will employ and maintain on the WORK a qualified supervisor or superintendent who shall have been designated in writing by the CONTRACTOR as the CONTRACTOR'S representative at the site. The supervisor shall have full authority to act on behalf of the CONTRACTOR and communications given to the supervisor shall be as binding as if given by the CONTRACTOR. The supervisor shall be present on the site at all times as required to perform adequate supervision and coordination of the WORK.

## **12. CORRECTIONS OF WORK**

12.1 The CONTRACTOR shall promptly remove from the premises all WORK rejected by the ENGINEER or OWNER for failure to comply with the CONTRACT DOCUMENTS, whether incorporated in the construction or not, and the CONTRACTOR shall promptly replace and re-execute the WORK in accordance with the CONTRACT DOCUMENTS and without expense to the OWNER and shall bear the expense of making good all WORK of the CONTRACTORS destroyed or damaged by such removal or replacement.

12.2 All removal and replacement WORK shall be done at the CONTRACTOR'S expense. If the CONTRACTOR does not take action to remove such rejected WORK within ten (10) days after receipt of WRITTEN NOTICE, the OWNER may remove such WORK and store the materials at the expense of the CONTRACTOR.

### **13. SUBSURFACE CONDITIONS**

13.1 The CONTRACTOR shall promptly, and before such conditions are disturbed, except in the event of an emergency, notify the OWNER by WRITTEN NOTICE of:

13.1.1 Subsurface or latent physical conditions at the site differing materially from those indicated in the CONTRACT DOCUMENTS; or

13.1.2 Unknown physical conditions at the site, of an unusual nature, differing materially from those ordinarily encountered and generally recognized as inherent in WORK of the character provided for in the CONTRACT DOCUMENTS.

### **14. PAYMENT TO CONTRACTOR**

14.1 Upon completion and acceptance of the WORK, the ENGINEER shall issue a certificate attached to the final payment request that the WORK shall been accepted under the condition of the CONTRACT DOCUMENTS. The entire balance found to be due the CONTRACTOR, including the retained percentages but except such sums as may be lawfully retained by the OWNER, shall be paid to the CONTRACTOR within thirty (30) days of completion and acceptance of the WORK.

14.2 The CONTRACTOR will indemnify and save the OWNER or OWNER'S agents harmless from all claims growing out of the lawful demand of SUBCONTRACTORS, laborers, workmen, mechanics, materials, and furnishers of machinery and parts thereof, equipment, tools, and all supplies, incurred in the furtherance of the performance of the WORK. The CONTRACTOR shall, at the OWNER'S request, furnish satisfactory evidence that all obligations of the nature designated above have been paid, discharged, or waived. If the CONTRACTOR fails to do so the OWNER may, after having notified the CONTRACTOR, either pay unpaid bills or withhold from the CONTRACTOR'S unpaid compensation a sum of money deemed reasonably sufficient to pay any and all such lawful claims until satisfactory evidence is furnished that all liabilities have been fully discharged whereupon payment to the CONTRACTOR shall be resumed in accordance with the terms of the CONTRACT DOCUMENTS, but in no event shall the provisions of this sentence be construed to impose any obligations upon the OWNER to either the CONTRACTOR, the CONTRACTOR'S Surety, or any third party. In paying any unpaid bills of the CONTRACTOR, any payment so made by the OWNER shall be considered as a payment made under the CONTRACT DOCUMENTS by the OWNER to the CONTRACTOR and the OWNER shall not be liable to the CONTRACTOR for any such payments made in good faith.

### **15. CLEAN-UP**

15.1 On the completion of the work, the CONTRACTOR shall, at his own expense, remove from the line and premises all surplus material and debris of every kind and description; reseed, fertilize, and straw disturbed areas; restore to the former condition all sidewalks, crosswalks, streets, pavements, fences and other public or private property which has been disturbed by reason of the construction of the work herein specified, in workman like manner.

## 16. INSURANCE

16.1 The CONTRACTOR shall purchase and maintain such insurance as will protect it from claims set forth below which may arise out of, or result from, the CONTRACTOR'S execution of the WORK, whether such execution be by the CONTRACTOR, any SUBCONTRACTOR, or by anyone directly or indirectly employed by any of them, or by anyone for whose acts any of them may be liable:

16.1.1 Claims under workmen's compensation, disability benefit and other similar employee benefit acts;.

16.1.2 Claims for damages because of bodily injury, occupational sickness or disease, or death of employees;

16.1.3 Claims for damages because of bodily injury, sickness or disease, or death of any person other than employees;

16.1.4 Claims for damages insured by usual personal injury liability coverage which are sustained (1) by any person as a result of any offense directly or indirectly related to the employment of such person by the CONTRACTOR, or (2) by any other person; and

16.1.5 Claims for damages because of injury to or destruction of tangible property, including loss of use resulting there from.

16.2 Certificates of Insurance acceptable to the OWNER shall be filed with the OWNER prior to commencement of the WORK. These Certificates shall contain a provision that coverages afforded under the policies will not be canceled unless at least fifteen (15) days prior WRITTEN NOTICE has been given to the OWNER.

16.3 The CONTRACTOR shall procure and maintain, at the CONTRACTOR'S own expense, during the CONTRACT TIME, Liability insurance as hereinafter specified:

16.3.1 CONTRACTOR'S General Public Liability and Property Damage Insurance including vehicle coverage issued to the CONTRACTOR and protecting the CONTRACTOR from all claims for personal injury, including death, and all claims for destruction of or damage to property, arising out of or in connection with any operations under the CONTRACT DOCUMENTS, whether operations by the CONTRACTOR or by any SUBCONTRACTOR employed by the CONTRACTOR or anyone directly or indirectly employed by the CONTRACTOR or by a SUBCONTRACTOR employed by the CONTRACTOR. Insurance shall be written with a limit of liability of not less than \$1,000,000 for all damages arising out of bodily injury, including death, at any time resulting there from, sustained by any one person in any one accident; and a limit of liability of not less than \$2,000,000 aggregate for any such damages sustained by two or more persons in any one accident. Insurance shall be written with a limit of liability of not less than \$1,000,000 for all property damage sustained by any one person in any one accident; and a limit of liability of not less than \$2,000,000 aggregate for any such damage sustained by two or more persons in any one accident. Hardin County Water District No. 2 shall be added as "additional insured" to the CONTRACTOR and the developer's general

liability insurance policy.

16.3.2 The CONTRACTOR shall acquire and maintain, if applicable, Fire and Extended Coverage insurance upon the PROJECT to the full insurable value thereof for the benefit of the OWNER, the CONTRACTOR, and SUBCONTRACTORS as their interest may appear. This provision shall in no way release the CONTRACT or CONTRACTOR'S surety from obligations under the CONTRACT DOCUMENTS to fully complete the PROJECT.

16.4. The CONTRACTOR shall procure and maintain, at the CONTRACTOR'S own expense, during the CONTRACT TIME, in accordance with the provisions of the laws of the state in which the WORK is performed, Workmen's Compensation Insurance, including occupational disease provisions, for all of the CONTRACTOR'S employees at the site of the PROJECT and in case any WORK is sublet, the CONTRACTOR shall require such SUBCONTRACTOR similarly to provide Workmen's Compensation Insurance, including occupational disease provisions for all of the latter's employees unless such employees are covered by the protection afforded by the CONTRACTOR. In case any class of employees engaged in hazardous work under this contract at the site of the PROJECT is not protected under Workmen's Compensation statute, the CONTRACTOR shall provide, and shall cause each SUBCONTRACTOR to provide, adequate and suitable insurance for the protection of its employees not otherwise protected.

16.5 The CONTRACTOR shall secure, if applicable "All Risk" type Builder's Risk Insurance for WORK to be performed. Unless specifically authorized by the OWNER, the amount of such insurance shall not be less than the CONTRACT PRICE totaled in the BID. The policy shall cover not less than the losses due to fire, explosion, hail, lightning, vandalism, malicious mischief, wind, collapse, riot, aircraft, and smoke during the CONTRACT TIME, and until the WORK is accepted by the OWNER. The policy shall name as the insured the CONTRACTOR, and the OWNER.

## **17. INDEMNIFICATION**

17.1 The CONTRACTOR will indemnify and hold harmless the OWNER and the ENGINEER and their agents and employees from and against all claims, damages, losses and expenses including attorney's fees arising out of or resulting from the performance of the WORK, provided that any such claims, damage, loss or expense is attributable to bodily injury, sickness, disease or death, or to injury to or destruction of tangible property including the loss of use resulting there from; and is caused in whole or in part by any negligent or willful act or omission of the CONTRACTOR, and SUBCONTRACTOR, anyone direct or indirectly employed by any of them or anyone for whose acts any of them may be liable.

17.2 In any and all claims against the OWNER or the ENGINEER, or any of their agents or employees, by any employee of the CONTRACTOR, any SUBCONTRACTOR, anyone directly or indirectly employed by any of them, or anyone for whose acts any of them may be liable, the indemnification obligation shall not be limited in any way by any limitation on the amount or type of damages, compensation or benefits payable by or for the CONTRACTOR or any SUBCONTRACTOR under workmen's compensation acts, disability benefit acts or other employee benefits acts.

17.3 The obligation of the CONTRACTOR under this paragraph shall not extend to the liability of the ENGINEER, its agents or employees arising out of the preparation or approval of maps, DRAWINGS, opinions, reports, surveys, CHANGE ORDERS, designs or SPECIFICATIONS.

## **18. ENGINEER'S AUTHORITY**

18.1 The ENGINEER shall act as the DEVELOPER representative during the construction period, shall decide questions which may arise as to quality and acceptability of materials furnished and WORK performed, and shall interpret the intent of the CONTRACT DOCUMENTS in a fair and unbiased manner. The ENGINEER will make visits to the site and determine if the WORK is proceeding in accordance with the CONTRACT DOCUMENTS.

18.2 .The CONTRACTOR will be held strictly to the intent of the CONTRACT DOCUMENTS in regard to the quality of materials, workmanship, and execution of the WORK. Inspections may be made at the factory or fabrication plant of the source of material supply.

18.3 The ENGINEER will not be responsible for the construction means, controls, techniques, sequences, procedures, or construction safety.

18.4 The ENGINEER shall promptly make decisions relative to interpretation of the CONTRACT DOCUMENTS.

## **19. LAND AND RIGHT-OF-WAY**

19.1 Prior to issuance of NOTICE TO PROCEED, the DEVELOPER shall provide all land and right-of-way necessary for carrying out and for the completion of the WORK to be performed pursuant to the CONTRACT DOCUMENTS, unless other wise mutually agreed.

19.2 The DEVELOPER shall provide to the CONTRACTOR information which delineates and describes the lands owned and rights-of-way acquired.

19.3 The CONTRACTOR shall provide at its own expense and without liability to the OWNER any additional land and access thereto that the CONTRACTOR may desire for temporary construction facilities, or for storage of materials.

## **20. GUARANTEE**

20.1 The CONTRACTOR shall guarantee all materials and equipment furnished and WORK performed for a period of one (1) year from the date of SUBSTANTIAL COMPLETION. The CONTRACTOR warrants and guarantees for a period of one (1) year from the date of SUBSTANTIAL COMPLETION of the system that the completed system is free from all defects due to faulty materials or workmanship and the CONTRACTOR shall promptly make such corrections as may be necessary by reason of such defects including the repairs of any damage to other parts of the system resulting from such defects. The OWNER will give notice of observed defects with reasonable promptness. In the event that the CONTRACTOR should

fail to make such repairs, adjustments, or other WORK that may be made necessary by such defects, the OWNER may do so and charge the CONTRACTOR the cost thereby incurred. The Performance BOND shall remain in full force and effect through the guarantee period.

## 21. TAXES

21.1 The CONTRACTOR will pay all sales, consumer, use, and other similar taxes required by the laws of the place where the WORK is performed.

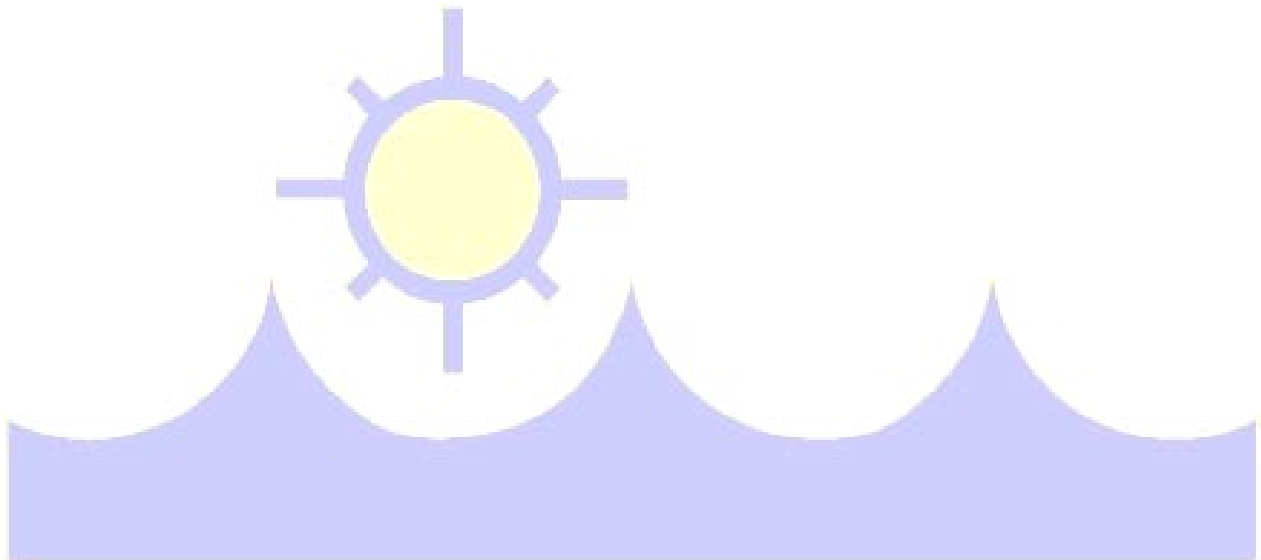

### III. TECHNICAL SPECIFICATIONS

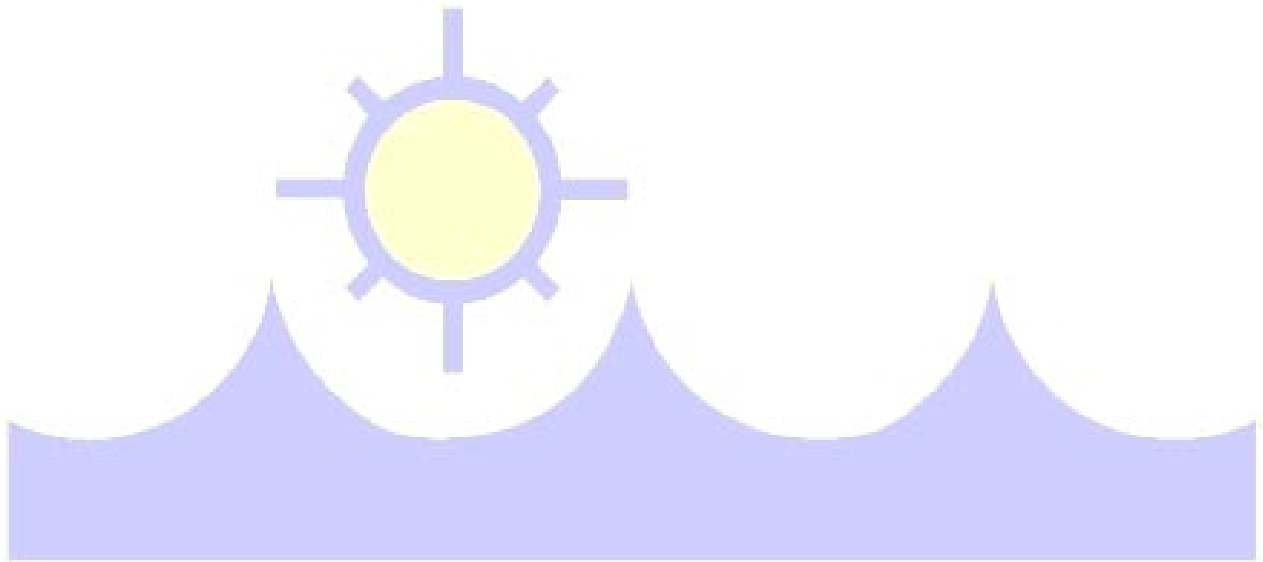

## WATER LINE SPECIFICATIONS

1. General. The CONTRACTOR shall furnish all labor, materials and equipment to install the water lines as shown on the plans and as specified herein.

The water lines may either be pressure-rated plastic pipe (PVC), municipal plastic pipe (MPVC) or ductile iron (DI).

The DEVELOPER will obtain all rights-of-way for operations through private property. It will also secure building permits and the permits for all pipe laid in highway rights-of-way. Any charge for inspections or other fees required will be responsibility of the DEVELOPER since the amounts of these are dependent upon the operation of the CONTRACTOR.

1.1 Department of Transportation Bonding. The Kentucky Department of Transportation will require that the OWNER post a bond for all work accomplished on their right-of-way. Each contract on which work is to be performed will be a separate application and will require a separate bond. Each permit will have conditions attached and these conditions will vary depending on the area where work is to be performed. In areas where traffic control may pose a problem, working hours may be limited. A copy of the encroachment permit will be provided to the CONTRACTOR. The CONTRACTOR will be responsible for knowledge of the permit's content and conditions in order that the construction may be accomplished in accordance with the specified requirements.

Should any additional bonds or requirements be imposed by the Kentucky Department of Transportation, the OWNER shall also be responsible for the bonding of the additional requirements.

## 2. Pipe and Fittings

2.1 Polyvinyl Chloride Rigid Pipe and Fittings. This specification covers rigid, pressure-rated, polyvinyl chloride pipe and fitting, hereinafter called PVC pipe and PVC fitting, for 1/2 inch through 12-inch. Pipe shall be as manufactured by Certainteed, North American, Diamond, J.M. or approved equal.

2.1.1 PVC Pipe. PVC pipe shall be extruded from Type 1, Grade 1, polyvinyl chloride material with a hydrostatic design stress of 2,000 psi for water at 73.4°F, designated as PVC 1120, meeting ASTM Specifications D-1784 for material and D- 2241 for pipe, latest revisions. Pipe shall also meet all applicable provisions of the Product Standards and shall bear the National Sanitation Foundation (NSF) seal of approval in compliance with NSF Standard No. 14. PVC pipe having a maximum hydrostatic working pressure of 160 psi (SDR26), 200 psi (SDR 21), 250 psi (SDR17), or 315 psi (SDR13.5) shall be used as shown on the Plans.

Samples of pipe and physical and chemical data sheets shall be submitted to the DISTRICT for review and determination of compliance with these specifications before pipe is delivered to job. The pipe shall be homogeneous throughout and free from cracks, holes, foreign inclusions or other defects.



The workmanship, pipe dimensions and tolerances, outside diameters, wall thickness, eccentricity, sustained pressures (ASTM D-1598), burst pressures (ASTM D-1599), flattening, extrusion quality (ASTM D-2152), marking and all other requirements of the Product Standard PS 22-70 shall be conformed with in all respects. No pipe, 2 inches in diameter or larger, with a wall thickness less than 0.090 inches may be used.

Pipe shall be furnished in 20 feet or 40 feet lengths. The pipe may be doubled plain end or with bell on one end. Male ends of pipe must be beveled on the outside. Pipe shall have a ring painted outside the male end or ends in such a manner as to allow field checking of setting depth of pipe in the socket. This requirement is made to assist construction superintendents and inspectors in visual inspection of pipe installation.

Pipes must be delivered to job site by means, which will adequately support it, and not subject it to undo stresses. In particular, the load shall be so supported that the bottom rows of pipe are not damaged by crushing. Pipe shall be unloaded carefully and strung or sorted as close to the final point of placement as is practical. Pipe must not be exposed to direct rays of sun for an extended period of time. If pipe is not to be installed shortly after delivery to the job site, it must be stored in a shaded location and strung as needed.

2.1.2 PVC Pipe Jointing. Pipe shall be joined with slip-type joints with rubber gaskets. Pipes with bells shall have all parts of the bell, including the gasket groove, made from the same extruded piece, integral with the pipe, and shall be thickened to meet standard dimension ratios of wall thickness to outside diameter. This manufacturing procedure shall be the normal practice of the pipe manufacturer and proven by past performance of pipe in service. The gasket groove shall be constructed such that gasket rollout will not occur. Rubber gaskets shall conform to ASTM 3139.

Joint lubricant shall be of the type recommended by the manufacturer for their pipe. Lubricant shall be water soluble, non-toxic and have no objectionable properties.

2.1.3 PVC Couplings. Where PVC couplings are used, they shall be of the same material as the pipe and may be of the molded or extruded type. PVC couplings shall have a minimum rating of 200 psi for continuous operation at 73.4 degrees F.

2.1.4 Fittings Ductile iron mechanical joint type fittings with appropriate adaptors shall be used with PVC pipe. All such fittings shall be approved by the pipe manufacturer, and a complete data sent to the DISTRICT, including the manufacturer's approval, for review. Fittings shall comply with AWWA C-110 or C-153 and shall be manufactured for the size and pressure class of the line on which they are used. Use of transition gaskets will not be allowed unless specifically approved by the pipe manufacturer. Coatings and lining shall be in accordance with 2.3.7.F of this section of the Specifications.

2.1.5 Service Connections. All service connections on PVC lines shall be made by means of bronze service clamps manufactured specifically for use with PVC pipe, with Mueller threads, Mueller Catalog No. H-134 or approved equal. Whenever possible, corporation stops shall be installed in plastic lines before conducting hydrostatic tests.

2.2 Municipal Polyvinyl Chloride (MPVC) Pressure Pipe. This specification covers the requirements for AWWA approved Polyvinyl Chloride Pressure Pipe for water supply and distribution systems.

2.2.1 MPVC Pipe. MPVC pipe shall meet the requirements of AWWA C900-75, latest revision, “Standard for Polyvinyl Chloride (PVC) Pressure Pipe, 4" through 12" for water” and shall be furnished in cast-iron pipe equivalent outside diameters with rubber-gasketed separate couplings. Pipe shall be as manufactured by Certainteed, North American, Diamond, J.M., or approved equal.

MPVC pipe and couplings shall be made from Class 12454-A or Class 12454-B virgin compounds as defined in ASTM D-1784. The standard code designation shall be PVC 1120. The PVC compounds shall be tested and certified as suitable for potable water products by the NSF Testing Laboratory and shall carry the NSF approval marking.

Solvent-cement couplings or joints shall not be used. PVC joints using elastomeric gaskets shall be tested as assembled joints and shall meet the laboratory performance requirements specified in ASTM D-3139.

Pipe and couplings shall be pressure Class 100, DR 25 (Dimension Ratio), pressure Class 150, DR 18, or pressure Class 200, DR 14 as shown on the plans.

Pipe and couplings shall be marked as follows:

- a. Nominal size and OD base.
- b. Material code designation (PVC 1120).
- c. Dimension ratio number.
- d. AWWA pressure class.
- e. AWWA designation number (AWWA C900).
- f. Manufacturers name or trademark and projection record code.
- g. Seal of the NSF Laboratory.

Pipe and couplings shall meet or exceed the following test requirements:

<u>Sustained Pressure</u>	=	<u>ASTM D-1598 (1000 Hrs.)</u>
<u>DR</u>		<u>Sustained Pressure</u>
14		600 psi
18		500
25		350

<u>Burst Pressure</u>	=	<u>ASTM D-1599 (60-70 seconds)</u>
<u>DR</u>		<u>Minimum Burst Pressure</u>
14		985
18		755
25		535

Hydrostatic Integrity - Each standard and random length of pipe shall be proof-tested at four times its rated class pressure for a minimum of 5 seconds. Bells or couplings shall be tested with pipe.

Flattening - The pipe shall not split, crack, or break when tested by the parallel-plato method as specified by ASTM D-2241.

Extrusion quality - The pipe shall not flake or disintegrate when tested by the acetone-immersion method as specified in ASTM D-2241.

Standard length - Pipe shall be furnished in standard laying lengths of 20 ft. + 1 in. A maximum of 15 percent of each pipe size may be furnished in random lengths of not less than 10 ft. each.

2.2.2 MPVC Pipe Jointing. Pipe shall be joined with slip-type joints with rubber gaskets. Manufacturing and installation procedures shall be as recommended by the manufacturer and as described for PVC pipe in Section 2.1.2 of this specification.

2.2.3 Fittings. Fittings for municipal PVC shall be ductile iron only. Fittings shall be mechanical joint. Fittings shall be manufactured for the size and pressure class of the line on which they are used and shall manufactured for the size pressure class of the line on which they are used and shall comply with AWWA C-110 or C-153. Coatings and lining shall be in accordance with subsection 2.3.7.F of this section of the Specifications.

2.2.4 Service Connections. Service connections shall be made by means of bronze service clamps manufactured specifically for use with municipal PVC pipe. Clamps shall be Mueller Catalog No. H-161 or approved equal.

2.2.5 Underground Marking Wire. At all locations where PVC pipe is utilized, a detectable underground marking wire shall be secured to the top of above the pipe with duct tape. The wire used shall be No. 12 insulated copper wire. Extreme care shall be exercised in connecting and taping splices and joints to assure continuity. At each valve box the wire shall be looped to the surface extending 12-inches above the concrete valve box pad (see Std. Dwg. for valve). When the entire project or pipeline segment is complete, including meter installation and leak repairs, the locating wire system shall be checked for continuity.

2.3 Ductile Iron Pipe. The specifications cover ductile iron pipe (3-inch diameter and greater) to be used in water transmission systems with mechanical joints, rubber ring slip type joints or flanged joints.

2.3.1 General. Ductile iron pipe shall be designed in accordance with AWWA H3 (ASA A21.50) and for pressures and conditions as stated in these specifications or called for on the plans. Ductile iron pipe shall conform to AWWA C-151 (ASA A21.51).

2.3.2 Minimum Nominal Thickness. The specified thickness will be determined for the given internal and external loading requirements in accordance with ASA A21.50. The class of pipe, wall thickness, and coatings required will be shown on the plans for all ductile iron pipe installation.

2.3.3 River Crossing Pipe. River crossing pipe shall be ductile iron, Flex-Lok as manufactured by the American Cast Iron Pipe company or equal conforming to the appropriate requirements of ANSI/AWWA C150/A21.50 and ANSI/AWWA C151/A21.5 with a thickness class of 54.

2.3.4 Lengths. Pipe may be furnished in 12, 16, 16 1/2, 18 or 20 feet nominal laying lengths.

2.3.5 Testes. Hydrostatic and acceptance tests shall be in accordance with AWWA Specification C-106 for "Cast Iron Pipe Centrifugally Cast In Metal Molds" or C-108 for sand molds. The District shall be provided with two (2) copies of each of the following tests for each project involved:

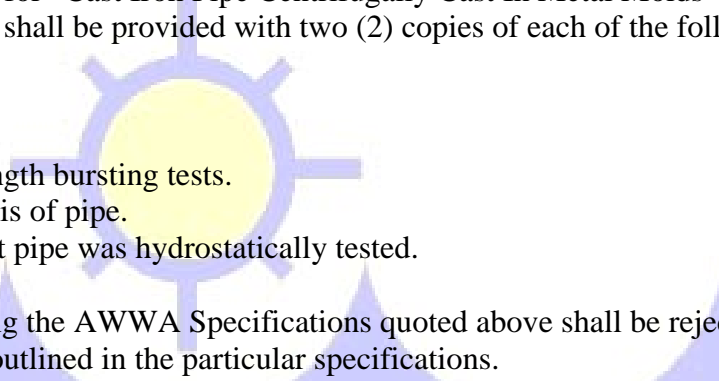
- 
- a. Talbot strip test
  - b. Ring and full length bursting tests.
  - c. Chemical analysis of pipe.
  - d. Certification that pipe was hydrostatically tested.

Any pipe not meeting the AWWA Specifications quoted above shall be rejected in accordance with the procedure outlined in the particular specifications.

2.3.6 Marking. The net weight, class or nominal thickness and sampling period shall be marked on each pipe.

2.3.7 Pipe Joints for Ductile Iron Pipe. Pipe joints shall be mechanical joint, rubber ring slip joint, flanged, or locked mechanical joint as shown on the plans.

#### A. Mechanical Joint

Mechanical joints are to be furnished according to AWWA Specifications C-111. All pipe joints must be furnished complete with all accessories. Mechanical joint bolts and nuts shall be of alloy cast iron or alloy steel (Corten type such as U.S. Alloy) or approved equal. Rubber gaskets shall be made of plain first grade rubber, free of imperfections and porosity. Hardness shall be 70 to 75 durometer.

## B. Rubber Ring Slip Joint

Rubber ring slip joint shall be equal to AWWA C-111-64 or latest revision. The joints shall be of the following materials:

- a. Rubber ring gasket compressed in groove in bell of pipe.
- b. Beveled spigot end of pipe for initial centering into rubber gasket in bell.

## C. Locked Mechanical Joint

Locked mechanical joints shall be equal to Clow Corporation's "Locked Mechanical Joint".

## D. Ductile Iron Flanged Pipe and Special Coupling

a. Flanged Pipe. All ductile iron flanged pipe shall have flanges faced and drilled, 125 pound in accordance with ASA A21.10 (AWWA C-110) unless otherwise specified on the Drawings. Flanges may be cast integrally with the pipe or they may be screwed on specially designed long hub flanges, refaced across both face of flange and end of pipe. Flanged pipe shall be in accordance with ASA A21.6 (AWWA C-106) Specifications, latest revision, and be the class called for on the plans. Where plain ends of flanged and plain end pipe fit into mechanical joint bells, centrifugally cast pipe shall be used. Flanged pipe for water service shall be cement lined and bituminous coated the same as written herein for bell-joint pipe.

b. Special Coupling. Flexible couplings for flanged pipe shall be a mechanical joint cast to a special flanged joint using a neoprene O-ring in place of the usual 1/16 inch rubber ring gasket. The mechanical bell and special flanged joint piece shall be of high-grade gray cast iron (ASTM A48-56, AWWA C-100-54T) with bolt circle, bolt size and spacing according to ASA Specifications. Mechanical joint follower flange shall be of ductile iron ASTM A399 or malleable iron ASTM A47, Grade 35018 or 32510, latest revision with high strength/weight ratio design.

Bolts shall be fine-grained high tensile malleable iron with malleable iron hexagon nut. Stainless steel nuts shall be used in vaults and vet wells. Where pressures may exceed 20 pounds, anchor studs shall be included with spigots of pipes connected drilled to receive ends of studs.

E. All items used for jointing pipe shall be furnished with the pipe and tested before shipment. The joints shall be made with tools and lubricant in strict conformity with the manufacturer's instructions. Two (2) copies of such instruction shall be delivered to the District at start of construction.

F. Coatings and Lining. All buried ductile iron pipe shall have manufacturer's outside coal tar asphaltic base coating and a cement lining and bituminous seal coat on the inside. Cement mortar lining and a bituminous seal coat inside shall conform to ANSI A21.4 (AWWA C-104) latest revision.

All pipe and fittings housed and in vaults shall be lined and coated on the inside as specified herein for buried ductile iron pipe and fittings, but shall be left uncoated on the outside so that it may be painted without the use of tar stop.

G. Fittings for Ductile Iron Pipe. Ductile iron mechanical, rubber ring slip and flanged joints shall conform to ASA Specifications A21.10 (AWWA C-110) for centrifugally cast iron water pipe. Mechanical joints shall also conform in all respects to ASA 21.11 (AWWA C-111). All fittings shall be manufactured for the size and pressure class of the pipeline in which they are to be used. All fittings shall be furnished complete with all joint accessories. All ductile iron pipe fittings for water, sewer, air, gas and force main service shall be bituminous coated outside and lined on the inside same as the line on which they are installed.

2.4 Polyethylene Pipe. This pipe is used primarily for stream crossings, roadway crossings, and other special applications in locations indicated on the DRAWINGS. The required pressure class shall be as shown on the DRAWINGS.

The pipe shall be PE 3408 high density, high molecular weight polyethylene pipe equal to Performance 4000 (Ductile Iron Pipe Size). The pipe shall meet or exceed the following specifications:

<u>Property</u>	<u>Test Method</u>	<u>Unit</u>	<u>Nominal Value</u>
a. Density	ASTM D1505	gm/cm <sup>3</sup>	0.955
b. Melt Index	ASTM D1 238 (Cond E)	gm/10min	0.11
c. Flexural Modulus	ASTM D790	psi	135,000
d. Tensile Strength	ASTM D638	psi	3,200
e. HDB @ 73°F	ASTM D2837	psi	1,600
f. UV Stabilizer	ASTM D1 603	% c	2.5
g. Hardness	ASTM D2240	Shore "D"	65
h. Compressive Strength (Yield)	ASTM D695	psi	1,600
i. Tensile Strength @ Yield (Type IV Spec.)	ASTM D638 (2"/min)	psi	3,200
j. Elongation @ Yield	ASTM D638	%, minimum	8
k. Tensile Strength @ Break (Type IV Spec.)	ASTM D638	psi	5,000
l. Elongation @ Break	ASTM D638	%, minimum	750
m. Modulus of Elasticity	ASTM D638	psi	130,000
n. Linear Thermal Expansion Coefficient	ASTM D696	in/in/°F	1.2 x 10 <sup>-4</sup>
o. Thermal Conductivity	ASTM D1 77	BTU-in/ft <sup>2</sup> /hrs °F	2.7
p. Brittleness Temperature	ASTM D746	°F	<-180
q. Heat Fusion Condition	-	psi @°F	75 @ 400
r. Material Designation	PPI	PE 3408	
s. Material Cell Classification	ASTM D3350	345434C	

The pipe shall be joined by the butt fusion technique utilizing controlled temperatures and pressures to produce a fused, leak-free joint that has equal or greater strength than the pipe itself in both tension and hydrostatic loading. The joining system shall be equal to Phillips butt fusion joint system.

Transitions to the continuing pipeline shall be made with the appropriate fittings to maintain the integrity of the piping system as recommended by the pipeline manufacturer.

Drawings showing details of the installation shall be submitted to the DISTRICT for approval prior to installation.

3. Hauling and Storage. The CONTRACTOR shall notify the DISTRICT when pipe will be received on the job so that proper arrangements may be made for inspecting the unloading and stringing, as well as inspecting and examining the pipe materials.

The CONTRACTOR will be required to deliver all equipment and other materials and place same as and where required for installation. Care must be exercised in the handling of all materials and equipment and the CONTRACTOR will be held responsible for all breakage or damage to same caused by his workman, agents, or appliances for handling or moving. Pipes and other casting shall in no case thrown or dropped from cars, trucks, or wagons to the ground, but some shall be lowered gently and not allowed to roll against or strike other castings and unyielding objects violently.

Pipes and other casting may be distributed at places that will not interfere with other building operations and unloaded, or yarded and distributed as required, as the CONTRACTOR may elect. Valves, castings, fabricated metal, reinforcing steel, etc. shall be yarded or housed in some convenient location by the CONTRACTOR and delivered on the ground as required. All equipment and materials subject to damage from the weather, dampness, changes in temperature, or exposure shall be protected by a dry, weatherproof enclosure until ready for installation or use. The cost of all hauling, handling, and storage shall be included in the prices bid for equipment and materials in place. The District takes no risk or responsibility for fire, flood, theft, or damage until after the final acceptance of the work.

4. Lines and Grades. The CONTRACTOR will be required to accomplish any detailed layout, including that required for establishing the grade of the pipeline.

5. Trench Excavation

5.1 General. This section describes the acceptable methods of trenching for the installation of pressure pipe and casing pipe in an open trench.

Trenching may be accomplished by means of a backhoe, trenching machine or by hand depending on the construction area.

At the CONTRACTOR'S option, trenching, by a trenching machine or by backhoe is acceptable except as noted below:

Where the pipeline is being constructed close to other utilities, structures, building, or large trees, and it is reasonable to anticipate possible damage from the use of a backhoe, then trenching shall be made by hand methods.

The PROJECT includes all trenching necessary for installation of all pipelines as planned and specified. Trenching shall include all clearing and grubbing, including all weeds, briars, small trees, stumps, etc. encountered in the trenching. The CONTRACTOR shall dispose of any such material by burning, burial, or hauling away (or as noted on the drawings), at no extra cost to the OWNER. It shall be the CONTRACTOR'S responsibility to notify the appropriate State and local Air Pollution Control agencies when he conducts open burning of refuse. Ornamental shrubs shall be removed, protected, and replanted.

Trenching also includes such items as minor street, road, sidewalk, pipe and small creek crossings; cutting, moving or repairing damage to fences, poles, or gates and other surface structures regardless of whether shown on the plans.

The CONTRACTOR shall protect existing facilities against danger or damage while pipeline is being constructed and backfilled, or from damage due to settlement of this backfill. In case of damage to any existing structures, repair and restoration shall be made at once and backfill shall not be replaced until this is done. In all cases, restoration and repair shall be such that the damaged structures will be in as good condition and serve its purpose as completely as before and such restoration and repair shall be done without extra cost to the DISTRICT.

The use of trench-digging machinery will be permitted except where its operations will cause damage to trees, buildings or existing structures above or below the ground. At such locations hand methods shall be employed to avoid such damage. All excavated materials shall be piled in a manner that will not endanger the work and will avoid obstructing sidewalks and driveways. Gutters shall be kept clear or other satisfactory provisions made for street drainage.

All excavation shall be open trenches, except where the drawings call for tunneling, boring, or jacking under structures, railroads, sidewalks and roads. The construction procedure for these types of excavation is described elsewhere in these specifications.

All trench excavation shall be termed unclassified and costs shall be included in the unit price bid for the pipe.

**5.2 Clearing.** The CONTRACTOR shall accomplish all clearing and/or grubbing as required for the construction under this contract. Clearing and grubbing shall include the cutting and removal of trees, stumps, brush, roots, logs, fences and other loose or projecting material and natural obstructions which, in the opinion of the DISTRICT, must be removed to properly prosecute the completion of construction and operate the facilities upon completion of construction. Trees, unless designated otherwise on the plans, shall remain and be properly protected. Ornamental shrubs, planting, fences, walls, etc. shall be removed and replanted or replaced or protected from the construction activity. Clearing and/or grubbing shall be incidental to the various bid items and no additional compensation will be paid for same.

**5.3 Trench Depth.** Trenches shall be excavated to the line and grade required for the installation of pipe at the elevations indicated on the plans. The minimum depth of cover shall be 30 inches above the top of the pipe, unless shown otherwise on the plans or on the Standard Details. In all cases, the pipe shall be installed a minimum of 30" below the elevation of the



finished roadway immediately adjacent to the pipe. When the pipe is laying in or on solid rock, the minimum depth of cover shall also be 30 inches above the top of the pipe. Excavation, except as required for exploration, shall not begin until the proposed work has been staked out. Materials which are not required for backfill and site grading shall be removed and disposed of as directed by the DISTRICT. Excavation shall be of sufficient depth to allow the piping to be laid on the standard pipe bedding in accordance with the Section 6 of this section. The trenches shall be excavated to a minimum of six (6) inches below the bottom of the pipe barrel in rock. In all cases where lines are under traffic a minimum cover of thirty-six (36") inches shall be provided. Should it be necessary to avoid existing utilities, culverts, outlets, or other structures, the water line shall be carried deeper at no additional expense.

5.4 Trench Width. Trench widths shall exceed the minimum width that will provide free working space on each side of the pipe and to permit proper backfilling around the pipe as shown in the accompanying table and unless specifically authorized by the DISTRICT, shall not be excavated to wider than two (2) feet plus the nominal diameter of the pipe at the top of the trench.

Before laying the pipe, the trench shall be opened far enough ahead to reveal any obstruction that may necessitate changing the line and grade of the pipe. Should the CONTRACTOR fail to accomplish this, and changes are required, they shall be at his sole expense. In rock, all ledge rocks, boulders, and large stones shall be removed to provide six (6) inches of clearance on each side and below all pipe and fittings.

MINIMUM TRENCH WIDTH

<u>Size</u>	<u>Width</u>	<u>Size</u>	<u>Width</u>
Up to 4" Pipe	1'-6"	15" Pipe	2'-8"
6" Pipe	2'-0"	16" Pipe	2'-8"
8" Pipe	2'-0"	18" Pipe	3'-0"
10" Pipe	2'-4"	20" Pipe	3'-2"
12" Pipe	2'-6"	21" Pipe	3'-4"
14" Pipe	2'-6"	24" Pipe	3'-8"

5.5 Shoring, Sheeting, and Bracing of Excavation. Where unstable material is encountered, or when the depth of the excavation in earth exceeds five (5) feet, the sides of the trench or excavation shall be supported by substantial sheeting, bracing or shoring. The design and installation of all sheeting, sheet piling, bracing or shoring shall be based on computations of pressure exerted by the materials to be retained under retaining conditions. Adequate and proper shoring of all excavations will be the entire responsibility of the CONTRACTOR. The Standards of the Federal Occupational Safety and Health Act and the Kentucky Department of Labor shall be followed.

The DISTRICT will not be responsible for determining requirements for bracing or sheeting.

5.6 Removal of Water. The CONTRACTOR shall provide for adequate removal of all water and the prevention of surface water from entering the excavation. The CONTRACTOR shall maintain dry conditions within the excavations until the backfill is placed. No additional compensation will be paid for replacement and/or stabilization of prepared excavations due to flooding and/or deterioration from extended exposure. All water pumped or drained from the excavation shall be disposed of in a suitable manner without damage to adjacent property or to other work under construction.

5.7 Pavement Removal. Pavement removal shall be as indicated on the plans or directed by the DISTRICT. When so required, or when directed by the DISTRICT, only one-half (1 1/2) of the street crossing or road crossing shall be excavated before placing temporary bridges over the side excavated, for the convenience of the traveling public. All backfilled ditches shall be maintained in such a manner that they will offer no hazard to the passage of traffic. The convenience of the traveling public and the property OWNERS abutting the improvements shall be taken into consideration.

All public or private drives shall be promptly backfilled or bridged at the direction of the DISTRICT. Pavement replaced shall be in accordance with Drawings of these specifications. Excavated materials shall be disposed of so as to cause the least interference and in every case the disposition of excavated materials shall be satisfactory to the DISTRICT.

5.8 Traffic Maintenance. The CONTRACTOR must “red light” and guard all open trenches or obstructions placed on the streets or sidewalks. The lights must be burning from sunset to sunrise in order to effectually warn and safeguard the public against dangers connected with open trenches, excavations and other obstructions. The CONTRACTOR shall be held responsible for any damage that may occur to persons or property by reason of the failure of the CONTRACTOR to properly “red light” and guard all open trenches or obstructions along the routes of the water lines. This CONTRACTOR at his own expense shall also maintain warning signs, barricades and a watchman or flagman to control traffic at such times, as his work would interfere with the flow of traffic. No excavation shall begin that may present a safety hazard unless the signs, barricades, lights, etc. are available to protect the open excavation at the conclusion of the day. The CONTRACTOR will comply with all Federal and State Occupational Safety and Health requirements for this type of construction. The CONTRACTOR shall also comply with all local and Kentucky Department of Highways requirements for signing and traffic control.

5.9 Line Location. The location of pipelines and their appurtenances as shown are those intended for the final construction. However, conditions may present themselves before construction on any line is started that would indicate desirable changes in location. In such cases, the DISTRICT reserves the right to make reasonable changes in line and structure locations without extra cost, except as may be determined by extra units of materials and construction actually involved. The DISTRICT is under no obligation to locate pipelines so they can be excavated by machine.

6. Bedding of Pipeline. In all cases the foundation for pipe shall be prepared so that the entire load of the backfill on top of the pipe be carried uniformly on the barrel of the pipe. The bells of the pipe shall not carry any of the load of backfill. The CONTRACTOR should refer to the Standard Details for pipe bedding shown in the plans. The bedding specifications shall govern the backfill from the bottom of the trench up to the centerline or spring line of the pipe.

6.1 Stable Earth Foundation. On all PVC pipelines, the trench bottoms shall be smooth and free of frozen material, clodded dirt and stones over 1/2" diameter. Bottom dirt left by trenching equipment will usually provide adequate material to level the trench bottom and provide bedding support for the pipe barrel. If the trench bottom is free of dirt, soft material may be shoveled off the sidewalls or shoveled under the pipe to insure proper pipe barrel bedding. In areas where the trench bottom is hard, a layer of soft backfill must be provided to insure the pipe barrel is properly cushioned. See the plans for proper bedding material depth.

If the foundation is good firm earth the pipe may be laid directly on the undisturbed earth provided the pipe barrel is supported for its full length.

Bedding on No. 9 stone, fine gravel, sand or compacted finely graded select earth shall be used to correct irregularities in the sub-grade. Where bell and spigot is involved, bell holes shall be excavated to prevent the bells from being supported on undisturbed earth.

As an alternative to the above method, excavation in earth may be undercut to a depth below the required invert elevation that will permit laying the pipe on a bed of granular material or finely graded select earth to provide continuous support for the pipe barrel. Bedding depth shall be as shown on the plans.

All ductile iron pipe shall be installed in accordance with Standard ANSI/AWWA C150/A21.50 Laying Condition Type 3 unless otherwise noted.

The bedding is not a separate pay item and shall be included as incidental expense.

6.2 Trenches In Rock. All installation in rock will utilize the undercutting method. Bedding will be with 6 inches crushed stone as shown in the Standard Details.

6.3 Unstable Trenches. If unstable material is encountered which may not provide suitable foundation for the pipe, the unstable material will be removed and an adequate layer of encasement concrete or other special bedding shall be placed for the pipe foundation in accordance with the Standard Details in the plans. Such "special pipe foundation" shall only be installed if directed by the DISTRICT in writing or on the plans.

## 7. Pipe Laying.

7.1 General. Proper instruments, tools and facilities satisfactory to the ENGINEER shall be provided and used by the CONTRACTOR for the safe and convenient prosecution of the work.

Each pipe manufacturer shall have an experienced representative on the job for at least one day at the commencement of jointing and laying operations.

Before any length of pipe is placed in the trench, a careful inspection shall be made of the interior of the pipe to see that no foreign material is in the pipe. In order to properly remove any foreign materials, a swab of necessary length is to be available at all times.

All pipe shall be lowered carefully into the trench, properly aligned and properly joined by the use of suitable tools and equipment, in such a manner as to prevent damage to water line materials and protective coatings and linings. Excessive scratching of the exterior surface of the pipe will be cause for rejection of the pipe.

Under no circumstances shall pipeline materials be dropped or dumped into the trench. The pipe and fittings shall also be inspected for the purpose of determining if they are sound and free from cracks. Laying of pipe shall be commenced immediately after excavation is started. Pipe shall be laid with bell ends facing in the direction of laying.

When pipe laying is not in progress, the open ends of pipe shall be closed by approved means to prevent entrance of trench water into the line. Whenever water is excluded from the interior of the pipe, adequate backfill shall be deposited on the pipe to prevent floating. Any pipe which has floated shall be removed from the trench and re-laid as directed by the ENGINEER. No pipe shall be laid in water or on frozen trench bottom, or whenever the trench conditions or weather are unsuitable for such work.

If any defective pipe and fittings shall be discovered after the pipeline is laid, they shall be removed and replaced with a satisfactory pipe or fitting without additional charge to the OWNER. Open ends of unfinished pipe lines shall be securely plugged or closed at the end of each day's work or when the line is left temporarily at any other time.

**7.2 Laying Ductile Iron Pipe.** Ductile iron bolted joint, rubber ring slip joint, and ball and socket river crossing pipe shall first be thoroughly cleaned at joints, then joined according to instructions and with tools recommended by the manufacturer. Three (3) copies of instructions shall be furnished by the ENGINEER and one (1) copy shall be available at all times at the site of the work. The lining inside ductile iron pipe must not be damaged by handling.

All pipes must be forced and held together, or "homed" at the joints, before sealing or bolting. Pipes must be aligned as each joint is placed, so as to present as nearly true, straight lines and grades as is practical, and all curves and changes in grades must be laid in such a manner that the manufacturer's recommended maximum deflection is not exceeded at any joint.

Cutting of pipe may be done by wheeled pipe cutters or saws, or by hammer and chisel, as the CONTRACTOR may elect, but the CONTRACTOR will be held responsible for breakage or damage caused by careless cutting or handling. All ductile iron pipe shall be installed in accordance with Standard ANSI/AWWA C150/A21.50 Laying Conditions Type 3 unless

otherwise noted.

Six (6) inches crushed stone bedding shall be used in rock. Sufficient space (limited to 2 feet longitudinally) shall be left out of 4 or 6-inch cushion for tightening of bolts where bolted joints are used. No pipe shall be laid resting on rock, blocking, or other unyielding objects. Jointing before placing in trench, and subsequent lowering of more than one section jointed together may be allowed, subject to the ENGINEER'S approval and direction.

When using pipe with push-on joints care must be exercised to make certain that the correct gasket is being used for the type of joint installed and that the gasket faces the proper direction. Before inserting the gasket, the groove and bell socket should be carefully cleaned of all dirt. If sand or dirt is permitted to remain in the groove, leaks may occur. Lubricant must be applied to bell socket, gasket and plain-end of pipe as required by manufacturer. Plain-end must be beveled before joint is made. Deflection required at the joint shall be obtained after the joint is made.

Cut pieces of ductile iron pipe 18 inches or more in length, shall be used in fitting to special conditions, and valves and fittings changes in grade and alignment, provided cutting is even enough to make first class joints and no cracks are evident.

7.3 Laying Plastic Pipe. The trench bottom must be smooth and uniform and the alignment must conform with the plans. Bedding and cover as specified herein and shown in the Standard Details is required.

To make a clean and unobstructed joint, it is necessary to wipe the ring, groove and pipe spigot free from all foreign materials at the time of assembly (welded joints will be allowed only in special cases and will be required as shown on the plans). The ring must be positioned properly in the fitting to receive the pipe by a worker who is not in contact with the lubricant. In general, the lubricant is applied to the spigot, (not the ring or groove). However, the manufacturer's instructions are to be followed in all cases. Only approved lubricant may be used in accordance with the manufacturer's recommendations. All plastic pipe shall be joined by hand.

Where good bedding conditions are attained PVC pipe smaller than 4 inches may be assembled outside the trench in longer sections (as conditions allow) and then lowered into the trench. At any time when improper bedding is discovered or the pipe is severely deflected the pipe will be removed from the trench and the condition corrected. Pipe in sizes 4 inch and above may be assembled outside the trench but must be lowered in to the trench as each joint is assembled. Regardless of installation methods all couplings must be inspected after laying in trench for proper insertion and alignment. Field cuts and bevels will be allowed in accordance with the manufacturer's recommendations for these operations. A new reference mark shall be installed before joining any field cut pipe. The same requirements for clearance from rock or other objects, thrust blocking and deflections shall apply to PVC pipe as for other pipe materials.

Municipal PVC pipe of all sizes must be assembled in the trench in strict accordance with the manufacturer's requirements.

7.4 Installation of River Crossing Pipe. The ball joint pipe shall be assembled and installed in accordance with manufacturer's recommendations. Installation shall be made at time of low flow, using cofferdams as necessary to divert stream flow. The ball joint pipe shall be laid and allowed to settle before jointing the pipe on each side of the stream. The ball and joint pipes shall be tested separately once in place to detect any leaks or bad joints. After connecting to the land pipe, it shall be tested the same as specified for the other water mains. See the DRAWINGS for additional installation requirements.

8. Backfilling. Backfilling must be stated as soon as practicable after pipe has been laid and joints hardened sufficiently, and jointing and alignment approved. Spading of crushed rock, sand, or mechanical tamping of earth, around pipe (as specifically required) between joints shall be the usual procedure as the laying progresses.

This is in order to avoid danger or misalignment from slides, flooding or other causes. The ENGINEER shall be given a minimum of 24 hours for inspection before inspection before backfilling. The backfill shall be crushed rock, sand, or finely divided earth free from debris, organic material, and stones, placed simultaneously on both sides of pipe to the same level by hand.

In backfilling of the lower part of the trench beginning at the top of the bedding, the backfill material shall be carefully and solidly tamped by hand or approved mechanical methods in 6" layers around the pipe and up to a point 8 inches higher than the top of the pipe. For PVC only the backfill shall be select material and be walked-in. Walking or working on the completed pipe line, except as necessary in tamping or backfilling, shall not be permitted until the trench has been backfilled to a point one diameter higher than the top of the pipe. The filling of the trench and the tamping of the backfill shall be carried on simultaneously on both sides of the pipe in such a manner that the completed pipe line will not be disturbed and injurious side pressures do not occur.

After the above specified backfill is hand placed, rock may be used in the backfill in pieces no larger than 18 inches in any dimension and to an extent not greater than one-half (1/2) the backfill materials used. If additional earth is required, it must be obtained and placed by the CONTRACTOR. Filling with rock and earth shall proceed simultaneously, in order that all voids between rocks may be filled with earth. Above the hand placed backfill, machine backfilling may be employed without tamping, (if not contrary to specified conditions for the location) provided caution is used in quantity per dump and uniformity of level of backfilling. Backfill material must be uniformly ridged over trench and excess hauled away, with no excavated rock over 1-1/2 inch in diameter or pockets of crushed rock or gravel in top 6 inches of backfill. Ridged backfill shall be confined to the width of the trench and not allowed to overlap onto firm original earth and its height shall not be in excess of needs for replacement of settlement of backfill. All rock, including crushed rock or gravel from construction, must be removed from yards and fields. Streets, roadways and walks shall be swept to remove all earth and loose rock immediately following backfilling. In case of street, highway, railroad, sidewalk and driveway crossings or within any roadway paving or about manholes, valve and meter boxes,

the backfill must be machine tamped in not over 4-inch layers, measured loose in accordance with the standard details. Where backfill is under paved driveways, streets, highways, railroads, sidewalks, paved parking areas and other areas where settlement is not allowed, crushed stone or coarse sand backfill only shall be used up to the paving surface. Crushed stone shall be Kentucky Department of Highways Standard

Specification No. 78 or finer. Coarse sand backfill shall be spread in layers not over 4 inches thick and thoroughly compacted. Sand may be moistened to aide compaction. Tunnels shall be backfilled in not over 3-inch layers, measured loose, with selected material suitable for mechanically tamping. If material suitable for tamping cannot be obtained, sand gravel or crushed rock (No. 78) shall be blown, packed or sluiced to complete fill all void spaces.

Where local conditions permit, pavement shall not be placed until 30 days have passed since placing backfill. Crushed stone is specified for roads and parking areas and sidewalks or their bases, shall be placed and compacted to the top of trench. Backfills shall be maintained easily passable to traffic at original gravel, until acceptance of project or replacement of paving or sidewalks.

Where the final surfacing is to be crushed stone, compacted earth backfill may be used in the trench within 6 inches of the top as shown in the Standard Details.

Railroad Company and Highway Department requirements in regard to backfilling will take precedence over the above general specification where they are involved.

Excavated materials from trenches and tunnels in excess of quantity required for trench backfill shall be disposed as shown on the plans or as directed by the ENGINEER.

The CONTRACTOR shall protect all sewer, gas, electric, telephone, water and drain pipes or conduits, power and telephone poles and guy wires from danger of damage while pipelines are being constructed and backfilled, or from danger due to settlement of his backfill.

In case of damage to such any existing structures, repair and restoration shall be made at once and backfill shall not be replaced until this is done. In all cases, restoration and repair shall be such that the damaged structure will be in as good condition and serve its purpose as completely as before under covering and such restoration and repair shall be done without extra charge.

No extra charge shall be made for backfilling of any kind, except as a part of the unit price bid for which it is subsidiary. No extra charge shall be made for supplying outside materials for backfill.

Before completion of contract, all backfills shall be reshaped, holes filled and surplus material hauled away, and all permanent walks, streets, driveway and highway paving, and sod, replaced (if such surface replacement items are included in the contract) and reseeding performed.

The line CONTRACTOR shall be responsible for clean-up, grading, seeding, sodding or otherwise restoring all areas that he disturbs within the work limits of other CONTRACTORS on this project.

Any deficiency in the quantity of material for backfilling the trenches or for filling depressions caused by settlement, shall be supplied by the CONTRACTOR.

9. Tie-ins to Existing Pipelines. This work shall consist of connecting new water pipes to the existing system where shown on the plans and shall include the necessary fittings, tapping sleeves, valves and necessary equipment and material required to complete the connection.

Knowledge of pipe sizes in the existing system may not be accurate, therefore, it is recommended that the CONTRACTOR check outside diameters of existing pipe and types of pipe prior to ordering the required accessories. No additional payment will be allowed for matching pipe and /or accessories when the proper size is not ordered.

Neither the OWNER nor the ENGINEER can guarantee the location of the existing lines. The CONTRACTOR shall verify the location of all existing water mains and valves pertaining to the proposed improvements before excavation is started.

The necessary regulation operation of the valves on existing water mains, to allow for the connections being made, shall be supervised by the ENGINEER. Before shutting down an existing water main or branch main for a proposed connection, prior approval for a specific time and time interval shall be obtained for a representative of the OWNER. At no time shall an existing main be shut down without the OWNER'S knowledge and permission.

Excavation to existing water mains shall be carefully made, care being exercised not to damage the pipe. The excavation shall not be of excessive size or depth beneath the pipe. The sides of the excavation shall be as nearly vertical as possible.

The CONTRACTOR shall be responsible for any damage to the existing system and any such damage shall be repaired to the satisfaction of the ENGINEER at the CONTRACTOR'S expense.

The CONTRACTOR shall verify, by field inspection, the necessary sizes, lengths and the type of fittings needed for each inter-connection. Typical connections are shown on the plans and any modifications or changes shall be subject to proposed water main needed for this work shall also be determined by field measurement as required.

The probing required to locate existing mains is not a separate pay item.

10. Pipe Entering Structures. Ductile iron, steel or PVC pressure pipe, 4-inch diameter or larger, entering structure below original earth level, unsupported by original earth for a distance of more than six (6') feet, shall be supported by Class B concrete, where depth of such support does not



exceed three (3') feet, and by Class B Concrete piers where depth exceeds three (3') feet in accordance with the Standard Details. All other pressure pipe entering building or basins below original earth level, which have more than 3 feet span between wall and original earth and having a cover of more than 24 inches of earth, or under roadway, shall be supported as shown on Standard Detail drawings, in order to prevent breakage from settlement of backfill about the structure. Concrete and reinforcing steel for such supports are to be included in the unit price of work to which it is subsidiary, and not as extra concrete, in order to discourage excessive excavation outside the limits of structures. Pipe entering structures shall have flexible joint within 16 inches of exterior of structure.

#### 11. Ownership of Old Materials.

Pipe - Unless otherwise indicated, all existing pipe that is to be abandoned that interferes with construction or is easily removed shall become the property of the CONTRACTOR. All pipe that is not easily removed or not required to be removed as a result of the new construction, shall be abandoned in place by this CONTRACTOR.

Pipe Line Fittings and Appurtenances - All pipe line fittings, valves, hydrants and other like appurtenances that are removed as a result of new construction shall be removed by this CONTRACTOR but shall become the property of the OWNER. All such fittings and appurtenances shall be delivered to a point by the CONTRACTOR. Said point shall be on the OWNER'S property and shall be designated by the ENGINEER.

Other Materials - All other materials or items that are to be removed, demolished, or abandoned as a part of this contract shall become the property of the CONTRACTOR and shall be disposed by him.

12. Thrust Blocks and Anchorage. Thrust blocks shall be installed whenever the pipe line changes direction, as at tees, bends, crosses, stops, as at a dead end; or at valves. The locations of thrust blocks depend on the direction of thrust and type of fitting. Their size and type depends on pressure, pipe size, kind of soil, and the type of fitting. Where thrusts act upward (as at vertical curves) the weight of the pipe, the water in the pipe and the weight of the soil over the pipe should be determined to make certain that the total weight is sufficient to resist upward movement. If there is not enough soil or if it will not compact over the pipe or it is too soft and mushy to resist movement, then ballast or concrete may be placed around the pipe in sufficient weight and volume to counteract the thrust. Where a fitting is used to make a vertical bend, the fitting may be anchored to a concrete thrust block designed to key in to undisturbed soil and to have enough weight to resist upward and outward thrust, since the new placed backfill may not have sufficient holding power.

Thrust blocks shall be constructed of not less than Class B concrete conforming to KBH Specification 601 and placed between the fitting and the trench wall. It is important to place the concrete so it extends to undisturbed (freshly cut) trench wall.

13. Maintenance of Flow of Drains and Sewers. Adequate provision shall be made for the flow of sewers, drains and water courses encountered during construction. Any structures which are disturbed shall be satisfactorily restored by the CONTRACTOR.

14. Interruption of Utility Services. No valve, switch or other control on any existing utility system shall be operated for any purpose by the CONTRACTOR without approval of the ENGINEER and the Utility. All consumers affected by such operations shall be notified by the CONTRACTOR as directed by the ENGINEER and utility before the operation and advised of the probable time when service will be restored.

15. Fencing. Where water supply line is being constructed in fields where stock is being grazed, CONTRACTOR shall provide temporary fence as approved by the ENGINEER around open trenches to prevent stock from falling in trenches. Where trenching operations should isolate grazing stock from their source of water, CONTRACTOR will either provide temporary bridging over trench or else provide water for such stock.

Where trench crosses near sound existing corner posts and existing fence is in good condition, fence may be taken loose, rolled back and stored until pipeline is completed at this point, then replaced by stretching tightly and thoroughly stapling. Additional posts will be provided and additional new fence shall provided when it is necessary to place the fence crossed by the water line in a condition equal to existing fence before waterline was constructed.

Where it is necessary to cut existing fence, new end posts shall be installed on each side for the water line and the old fence thoroughly stapled to these new posts before cutting. After pipe line is completed at this point, a new fence of galvanized wire (no. 9 gauge with No. 11 filler wires) shall be stretched between these new end posts and thoroughly stapled to existing posts and any new intermediate posts necessary to provide a good fence. Replacement of fences shall be on a replacement in-kind basis, and shall be considered incidental to laying of the lines and any additional cost shall be included in the unit price bid per lineal foot of pipe.

16. Protection of Adjacent Landscape. Reasonable care shall be taken during construction of water lines to avoid damage to vegetation. Ornamental shrubbery and tree branched shall be temporarily tied back, where appropriate, to minimize damage. Trees which receive damage to branches shall be trimmed of those branches to improve the appearance of the tree. Tree trunks receiving damage from equipment shall be treated with a tree dressing.

In the course of construction, the CONTRACTOR may deflect horizontal alignment of the water line to avoid trees and to keep from damaging their roots. The CONTRACTOR shall be fully responsible for setting all claims by private property owners concerning damage to trees and shrubs.

17. Coordination With Utilities. The Plans show the general location of existing utilities, such information having been determined from the utilities. However, such information shall be considered general and is not guaranteed by OWNER, ENGINEER, or the UTILITY.

Prior to construction, the CONTRACTOR shall arrange to meet with representatives of all utilities, and provide them with his anticipated work schedule. The CONTRACTOR shall have the utilities make their best determination of utility locations in the areas in which he is working. Throughout the progress of the work, such field marking of utilities shall be kept current.

Repairs to any utilities damaged by the CONTRACTOR shall normally be performed by the utility at the CONTRACTOR'S expense, unless the CONTRACTOR and the utility negotiate other understandings and/or procedures.

18. Blasting and Rock Excavation. The CONTRACTOR shall make his own investigation as he deems necessary to ascertain the sub-surface conditions to be encountered in the work.

All blasting operations shall be conducted in accordance with municipal ordinances, state and federal laws and Section 9, Explosives, of the "Manual of Accident Prevention in Construction", published by the Associated General Contractors of America, Inc. Soil particle velocity shall not exceed limit set by Kentucky law. All explosives shall be stored in conformity with said ordinances, laws and safety regulations. No blasting shall be done within five feet of any water mains, sewer lines, natural or manufactured gas lines, liquid petroleum product lines or other utilities. Any damage done by blasting is the responsibility of the CONTRACTOR and shall be promptly and satisfactorily repaired by him.

The CONTRACTOR shall use delay caps or other approved methods to reduce earth vibrations and noise. Mud capping, as defined in the above manual, will not be permitted on Sundays or after dark.

Prior to commencing with the work, the CONTRACTOR shall, during preconstruction conference with the OWNER and ENGINEER, state clearly his approach to performing the excavations on the project. He shall be familiar with the laws and ordinances covering blasting and shall also give consideration to the use of hydraulically operated rock breaking devices in lieu of blasting where considered necessary. If blasting is not handled in an expert manner at all times, the ENGINEER reserves the right to suspend blasting and require the work to proceed without it.

Prior to blasting, the CONTRACTOR shall make his own detailed survey of adjacent walks, curbs, retaining walls, house foundations, etc. to determine conditions prior to the work. Such a file of information, including photographs, may be certified in such a manner as the CONTRACTOR believes necessary since this information that may stand in his defense.

## INSTALLATION OF WATERLINE ACCESSORIES

### 1. GENERAL

The CONTRACTOR is to supply and install all valves, hydrants, blow-offs and other equipment at the locations shown on the plans in complete accordance with these specifications.

### 2. GATE VALVES (4" and larger)

All underground gate valves shall be the resilient seat-type, iron body, non-rising stem, fully bronze mounted, tar-coated outside and suitable for working water pressures of not less than 200 PSIG. Valves shall be of standard manufacture and of the highest quality both of materials and workmanship and shall conform to the latest revision of AWWA Specification C-509. Valves shall be furnished with flanged (exposed piping) or mechanical joint (buried piping) end connections suitable for connection to the pipe with which they are to be used. Gate valves shall have a clear water way equal to the nominal diameter, and shall be opened by turning to the left. The operating nut or wheel shall have an arrow cast in the middle, indicating the direction of opening. Each valve shall have the maker's initials, pressure rating and the year in which manufactured, cast on the body. Prior to shipment from the factory each valve shall be tested by hydraulic pressure of at least 300 pounds per square inch.

Underground valves shall be nut operated, unless other wise shown on the plans. Valve supplier shall furnish two standard stem iron wrenches for turning nut-operated valves. All underground valves which have nuts deeper than 30 inches below the top of valve box shall have extended stems with nuts located within 2 feet of valve box cap.

The valve maker is to supply the ENGINEER, through the bidder, within one week after award is made, complete catalogs or other material giving complete details and dimensions of valves and accessories. The ENGINEER'S approval shall be received by manufacturer prior to shipment of materials.

### 3. BUTTERFLY VALVES.

All butterfly valves shall be of tight closings, rubber or synthetic rubber seat type with seats securely fastened to valve body. No metal-to-metal seating surfaces will be permitted. Valves shall be bubble tight at the rated pressure in either direction and shall be satisfactory for applications involving throttling service and/or frequent operation and for applications involving valve operation after long periods of inactivity.

Valves shall be Class 250 suitable for working water pressure of 250 psi unless otherwise specified or noted on the plans.

Cast Markings: valve size, manufacturer's name, class, direction of opening, and year of casting.

The valve discs shall rotate 90\* from the full open position to the tight shut position.

The valve discs shall be cast/ductile iron with a welded nickel edge free of ribbing or protrusions which may collect solids. The disc-to-shaft connections shall be via polished 316 SS pins. Sprayed or plated discs are not acceptable. All disc seating edges shall be smooth and polished.

The shafts shall be turned, ground and polished. They shall be 300 Series or 400 Series Stainless Steel with diameters per AWWA Spec. C504-70, Class 75B. The shafts shall be of one-piece construction.

The shaft seals shall be of Hycar or Hypalon and shall be provided to prevent leakage into the bearing chest areas.

The valve bearings shall be Teflon coated, self-lubricating, stainless steel design and construction.

The valve seats shall be Neoprene or Hypalon and shall be simultaneously molded, vulcanized and bonded to the valve body of a rigid reinforcing ring.

### 3.1 OPERATORS

The valve operating mechanisms shall before counterclockwise opening. There shall be no external moving parts on valve or operator except the operator input shaft. Input shaft is to be operated by a 2-inch square-operating nut. Maximum required input force on the operator shaft to open and close the valve shall be 40 pounds. The total number of turns applied to the operating nut required to completely open the valve from a completely closed position shall not be not less than twice the nominal valve diameter. An extension stem shall be furnished if required to bring the operating nut within 3 ½ feet of finished grade. Extension stems shall be securely fastened to the valve stem. A stainless steel collar, 6-inches high, shall be welded to the operating gear box housing centered on the operating nut to hold the valve box in place and seal it against dirt. The diameter of the collar shall be such that it will accept the valve box.

The valves shall be manufactured by M & H, Dresser, Dezurik or approve equal.

## 4. AIR VALVES

### 4.1 AIR RELEASE VALVES

A valve designed to allow exhaust of small pockets of air from the water main while in use shall be installed where shown on the plans or where directed by the ENGINEER.

The air release valve shall have an iron pipe thread inlet in sizes shown in the valve schedule, cast iron body construction, and bronze trim, with all internal parts of stainless steel or bronze. The valve shall have an orifice size shown in the valve schedule. Valves shall be suitable for a working water pressure of 150 PSIG. The air release valve shall be mounted on 3/4", Schedule 80, galvanized steel riser pipe. The riser pipe shall be connected to the water main by use of a service clamp and a corporation stop as shown in the standard details. The riser shall also have a 3/4", bronze gate valve with a tee-handle, solid wedge type, inside I.P. threads, suitable for a 150 PSIG working water pressure. Equipment shall be as manufactured by Mueller, Ford, Crane, Val-Matic or approved equal.

Air release valves will be installed in the same type of box as is used for meters. The box shall be Ford Mueller or equal. The box may be cast iron, concrete or concrete pipe. The box must allow for adequate cover over the pipe at the installation.

### **AIR RELEASE VALVE SCHEDULE**

<u>Location</u>	<u>Inlet Size</u>	<u>Orifice Size</u>	<u>Model</u>
1. As shown on drawing	3/4"	3/32"	Val-Matic Model 22

#### 4.2 COMBINATION AIR VALVES (CAV)

Combination air release valves (single body, double orifice) shall be designed to allow large volumes of air to escape out the large air vacuum orifice when filling a pipeline and to close water tight when the liquid enters the valve. During large orifice closure, the small air release orifice shall open to allow small pockets of air to escape automatically and independently of the large orifice. The large air vacuum orifice shall also allow large volumes of air to enter through the orifice during pipeline drainage to break the vacuum. The body inlet must be baffled to protect the lower float from direct contact of the rushing air and water to prevent premature valve shut off. The top float must be protected in similar manner for the same purpose. The Buna-N seat must be fastened to the valve cover without distortion for drop tight shut off. All floats shall be heavy stainless steel, hermetically sealed; designed to withstand 1000 psi or more. The upper float shall be center guided for positive shut off. Valve exterior to be painted red lead TT86B Type IV for high resistance to corrosion. Materials certified to ASTM specifications as follows:

- Body & Cover & Baffle - Cast Iron
- Stainless Steel Float
- Buna-N Seat & Needle
- Plug & Bronze Foring
- Delrin Level Frame

ASTM A48 Class 30  
ASTM A240  
Nitrile Rubber ASTM SB 800  
ASTM D638

Combination air release valves shall be as shown in the valve schedule manufactured by APCO or equal. The valve shall be built for 300 psi service.

#### 4.3 CUSTOM COMBINATION AIR VALVES (CCAV)

Custom combination air valves (double body, double orifice) allow large volumes of air to escape out the large orifice when filling a pipeline, then close when liquid enters the valve. The small orifice Air Release Valve shall be an independent valve body, side connected to the large orifice Air and Vacuum Valve body with piping, and a 1" brass gate valve for isolation. While the large orifice is closed, the small air release orifice will open to allow small pockets of air to escape automatically and independently of the large orifice. The small orifice air release valve shall be an independently operated compound lever mechanism of cast stainless steel or bronze.

The large air and vacuum orifice shall also open and allow large volumes of air to enter the pipeline during pipeline drainage to break the vacuum. The large orifice float must be surrounded by a baffle for protection against direct forces of rushing air and water to prevent premature valve shutoff. The baffle must be a heavy integral cast part of the main valve body, not a loose piece.

The Buna-N seat shall be compression molded, a minimum 1/2" thick and fastened to the valve cover with shoulder screws to lock the seat in place without distortion, for drop tight shutoff. Both floats shall be heavy stainless steel, hermetically sealed. The large orifice float shall have a one piece rod to center guide it through stainless steel bushings into shut-off against seat.

The custom combination air valve shall be rated 300 psi. The small orifice shall operate (open) up to 150 psi.

All materials of construction shall be certified in writing to conform to ASTM specifications as follows:

Body & Cover	Cast Iron	ASTM A48, Class 30
Floats	Stainless Steel	ASTM A240
Needle & seat	Buna-N	ASTM A296 T316
Leverage Mechanism	Stainless Steel	FDA Approved for
Exterior paint	Phenolic Primer	Potable Water
	Red Oxide	Contact

Valve to be APCO Series 1800 custom combination air valve, as manufactured by Valve and Primer Corporation, or equal.

## 5. FIRE HYDRANTS

Work Included. Under this Item, the CONTRACTOR shall provide all labor, tools, equipment and materials to furnish and install fire hydrants with gate valves as shown on the drawing and as directed by the ENGINEER.

Hydrants shall be designed for 150 pounds working pressure or 300 pounds hydrostatic pressure and shall conform to the latest specifications of the AWWA. All working parts shall be bronze. The hose outlets and steamer nozzle shall be of such size and design that it will fit the present fire fighting equipment. Hydrants shall be designed so that no water will be lost when they are broken off and so they can be repaired with a repair kit. Design materials, and workmanship shall be similar and equal to the materials, and workmanship shall be similar and equal to the latest stock pattern ordinarily produced by the manufacturer. Length of barrel shall be such to provide ample cover over the connecting line. Working drawings and full description of hydrants shall be submitted to the DISTRICT before ordering. All hydrants shall have a 5 1/4 inch valve opening against pressure. The hydrants shall be equal to those manufactured by Kennedy. Four spanner wrenches for operation of the hydrants shall be furnished for the DISTRICT'S use.

Paint. Hydrants shall be painted one coat of primer and two finish coats of approved paint of color directed by the DISTRICT (Body – National Blue, Caps – Silver). Painting shall conform to AWWA C902-85, Section 4.2 Painting.

Installation. Hydrants shall be set at such elevations that the connecting pipe will have the same depth of cover as the distribution main. The hydrant shall be set upon a slab of stone or concrete not less than four inches thick and 15 inches square. The back of the hydrant opposite the pipe connection shall be firmly wedged against one and one-half square feet or enough of the vertical face of the trench with concrete to prevent the hydrants from blowing off the line. If the character of the soil is such, in the opinion of the DISTRICT that the hydrant cannot be securely wedged, bridle rod collars shall be used which shall be not less than three-fourths inch stock and shall be protected by a coat of acid resistant paint.

Not less than seven cubic feet of No. 9 stone shall be placed around the base of the hydrant to insure drainage. Before the No. 9 stone is placed and before it is backfilled the drain holes shall be inspected and thoroughly cleaned if necessary. The backfill around the hydrant shall be thoroughly compacted to the grade line in a manner satisfactory to the DISTRICT. Hydrants shall have the interior cleaned of all foreign matter before installation.

All hydrants will be installed with the pumper connection facing the main access road or as directed by the DISTRICT.

Stuffing boxes shall be tightened and the hydrants shall be inspected in open and closed position to see that all parts are in working condition.



## 6. VALVE BOXES

All valves (gate, air release, check, etc.) installed underground shall be installed in an approved valve box. Each gate valve shall be installed in a vertical position with a valve box. Valve boxes shall be of cast iron, two or three piece, slip-type consisting of a base, a center section and a top section with a cover marked "water". Where valve box is constructed in a paved area the box shall be a screw type box. The entire assembly shall be adjustable for elevation and shall be set vertically and be properly adjusted so that the cover will be in the same plane as the finished street surface (no more than 1/2" above ground in yards or pastures or 2" in unsodded areas) at the installation site and shall rest on concrete pads as shown in the Standard Details. The CONTRACTOR shall furnish 2 valve wrenches for the project.

## 7. BLOW-OFF VALVES

Blow-off valves shall be installed in accordance with the details and the specifications at locations shown on the plans and in other locations as directed by the ENGINEER. In some instances fire hydrants serve as blow-off valves. In general, blow-off valves are located at the end of mains for the purpose of clearing the main of sediment, obstacles or impure water. The CONTRACTOR should refer to the Standard Details for blow-off installation.

The blow-off pipe from the main to the flush valve shall be connected to the main by means of a tee. Do not use a corporation stop for this connection. The gate valve for the blow-off connection shall be a double disc gate valve in conformance with AWWA C500 for sizes under 4" and resilient seat gate valves in conformance with AWWA C509 for sizes 4" and larger. All pipe shall be galvanized pipe, Schedule 80, with class 300 malleable iron fittings. CONTRACTOR shall install a length of hose in each valve box as shown in the Standard Details. The valve enclosure shall be a Mueller Meter Box or equal with appropriate risers. The cover shall be of cast iron construction, 4 inches deep with a non-recessed lid, with cast letter "WATER" and a pentagon lock nut.

## 8. TAPPING SLEEVE AND VALVE

A Mueller tapping sleeve and valve or equal shall be used for making wet taps and shall be rated for a minimum working water pressure of 200 psi. CONTRACTOR shall ascertain the type and size of pipe to which the connection is to be made prior to selection. During the process of tapping an asbestos concrete main, the CONTRACTOR shall conform to OSHA Regulations governing the handling of hazardous waste. Pieces of asbestos concrete resulting from the tap shall be double bagged, placed in a rigid container, and disposed of in an approved landfill.

## 9. MEASUREMENT AND PAYMENT

Payment for gate valves, check valves and other special valves installed underground shall include all work necessary for a complete installation and shall include valve stem boxes or other valve boxes and box covers. Payment will be made at the unit price bid for the type and size of valve installation. Blow-offs and air release valves will be paid for under their respective bid price and is to include box and six (6) feet of pipe for blow-offs only. Excess pipe under bid price for pipe installed.

## SPECIAL ITEMS OF CONSTRUCTION IN WATER LINE INSTALLATION

### 1. GENERAL

These specifications govern special crossings, installations and construction procedures required to deal with unusual construction items or special requirements of governing agencies.

### 2. STATE HIGHWAY CROSSINGS

In all cases, these crossings will be made in compliance with the requirements of the State Highway Department. Such requirements will normally be described by the appropriated District Highway Office. In general, unless otherwise shown on the plans or directed otherwise by the DISTRICT, the crossing of all State Highways shall be accomplished by boring under the roadway. In addition, the crossing of service lines 1-1/2 inches and greater under rigid and flexible surfaced paved roads shall be accomplished by boring and jacking a casing pipe under said roadway. In certain cases, as shown on the plans, service lines of all sizes will require casing pipe installed with the crossing.

2.1 Open Trench Crossing. The trench shall be excavated to a minimum width that will allow the pipe installation. The trench walls shall be kept as nearly vertical as possible. The minimum specified cover above the pipe shall be maintained. The Standard Details section shows the requirements for open trench crossings.

The backfill in the trench under any roads, driveways, or parking areas where the open trench method is used shall be of the type shown in the Standard Details and shall be deposited and compacted in uniform layers not to exceed the depth shown in the Standard Details.

The surface of the road, driveway, or parking area shall be replaced with the same type of material as specified under pavement replacement.

2.2 Boring and Jacking. The work is herein defined as the operations in which both the operations in which both the boring by auger and the jacking of the casing pipe are done mechanically and in which the diameter of the casing pipe is too small to permit hand working at the heading of the casing pipe. Two basic methods are; (1) pushing the casing pipe into the fill or earth simultaneously as the boring auger drills out the ground; and (2) drilling the hole through the fill or earth and pushing the casing or carrying pipe into the hole after the drill auger has completed the bore.

A suitable approach trench shall be opened adjacent to the slope of the embankment, or adjacent to point of bored and jacked section as shown on the plans. The approach trench shall be long enough to accommodate the selected working room. Guide timbers or rails for keeping the casing pipe on line and grade shall be accurately set and maintained in the bottom of the approach trench and with heavy timber back-stop supports installed at the rear of the approach trench to adequately take thrust of the jacks without any movement or distortion.

It is paramount to the securing of acceptable tolerance limits of workmanship in the boring and jacking operation that extreme care be taken in the setting of all guides, rails and jacks to the end that casing pipe in final position be within the limits of acceptability for the placing and laying of the carrier pipes. The minimum cover of 36 inches under the roadway must be maintained. Additional depth may be required as shown on the plans.

In general, the diameter, thickness, style, joints and materials selected for casing pipe shall be as shown on the plans and shall be considered as "minimum" requirements, all subject to prior approval of the DISTRICT. In all cases, the approval for construction by agreement with the private company and/or construction permit issued by the State, County, or Municipal agency will be required before construction starts.

Steel casing pipe for road and railroad crossings using the boring and jacking method shall be steel, plain end, uncoated and unwrapped, and shall be furnished in at least 18-foot lengths. Steel pipe shall meet the requirements of ASTM Specification A-120 and AWWA C200. Pipes up to and including 4 inches in diameter shall be Schedule 40. Pipe larger than 4 inches shall have a wall thickness equal to or greater than 0.312 inches under railroads and 0.250 for all other uses. The inside diameter of all casing pipes shall be a minimum of four (4") inches greater than the largest outside diameter of the carrier pipe, joint or coupling.

The steel casing pipe shall be bored and/or jacked in place at the locations as shown on the plans or as directed by the DISTRICT. All joints between lengths shall be solidly welded with a smooth non-obstructing joint inside. Any field welding shall be performed by a certified welder, and shall be in accordance with AWWA C206. The casing pipe may be extended beyond the boring limits by open trenching as shown in the Standard Details. This would apply when casing is required from right-of-way or ditch line to ditch line. Open trenching at jacked or bored locations will be allowed no closer than 3 feet from edge of pavement.

The ends of the casing pipe shall be plugged and made watertight in a manner acceptable to the DISTRICT prior to backfilling. Casing seals as manufactured by Pipeline Seal & Insulator, Inc. (PSI), Advanced Products & Systems, Inc. (APS) or equal shall be used.

Where road crossings are made using plastic pipe or copper, the location of joints under the roadway should be avoided by using lengths of adequate dimension for the crossing. This principle also applies to other types of pipe where sufficiently long lengths are available.

### 3. RAILROAD CROSSINGS

At all railroad crossings, cover pipe (casing) for water lines (carried pipe) shall be jacked or pushed beneath tracks and the carrier pipe joined and pushed through the cover pipe. Detailed drawings of railroad crossing including the length of casing and depth below track are shown in the plans. CONTRACTOR shall obtain and pay for services of a representative of the railroad to direct the CONTRACTOR'S operations while on the railroad property when required by the railroad.

#### 4. CREEK CROSSINGS

4.1 Special Creek Crossing. Where required on the plans or instructed by the DISTRICT, the CONTRACTOR shall construct a special creek crossing as shown in the Standard Details. Crossing shall be scheduled for construction in times of low flow, if practicable, other wise cofferdams of sand bags or clay shall be used to divert the stream flow while crossing is made. Concrete shall not be placed under water and CONTRACTOR shall provide suitable pumps to keep water out of trench excavation during stream crossing construction. Special creek crossings shall be designated as Type A or Type B as contained in the Standard Drawings.

4.2 Normal Earthen Creek Crossing. Where the stream crossing is made in earth or other beds which are stable (no casing or anchorage required), then the pipe will be laid in a narrow trench at the depth specified in the Standard Details to maintain the required cover between pipe and stream bed. Initial backfill will be mechanically compacted. Trench backfill in any stream crossing area from one (1) foot above the top of the pipe shall consist of trench excavated rock, if available. No extra payment will be made above normal construction for this type of creek, crossing.

#### 5. RIVER OR LAKE CROSSING

Crossings in rivers or lakes where the pipe cannot be laid in a trench shall normally be made with ductile iron pipe having ball and socket joints or polyethylene pipe as indicated on the DRAWING. Details for any required installations of this type including pipe required; number, size and location of anchors; and installation technique are shown in the plans.

#### 6. BRIDGE CROSSINGS

Wherever possible bridges will not be utilized for stream crossings. However, where it is necessary for the water line to be attached to bridges, the pipe shall be securely fastened to bridge stringers or beams using supports as dimensioned and located in the plans. The carrier pipe shall be insulated with Vermiculite or other approved material to prevent freezing. Expansion joints to allow for movement of the bridge will be required as shown on the plans.

#### 7. WATER LINE AND SEWER LINE SEPARATION

7.1 General. Whenever sewer lines cross, or are adjacent to, each other, special precautions shall be taken.

7.2 Parallel Water and Sewer Lines. Water lines must, if possible be located a minimum lateral distance of 10 feet from any existing or future sewer lines measured for outside diameters. Where water lines and sewer lines must be placed in the same trench, the water line must be located on a shelf, 2 feet above and 2 feet to the side of the sewer line. Whenever this condition cannot be met, and upon direction from the DISTRICT, the water line shall be uncovered and encased with concrete per the standard encasement detail.

7.3 Crossing Water and Sewer Lines. Wherever sewer lines and water lines cross, it is desirable, if practical, that the sewer line be at least 24 inches below the water line.

Where it is not practical to provide such a separation, care shall be taken to ascertain that the existing water line or existing sewer line is in good sound condition and that no evidence of joint leakage is known in the vicinity. If any such evidence does exist, the existing line shall be exposed by the CONTRACTOR at least 10 feet each side of the new pipe crossing, carefully examined and any defects positively corrected. The DISTRICT will arrange for examining and correcting any defects in the existing lines, but the CONTRACTOR shall cooperate in every way possible.

When the water line must be below or less than 2 feet above the sewer line, the CONTRACTOR shall encase the water line 10 feet in each direction from the crossing as directed by the DISTRICT. This encasement should only be accomplished when directed by the DISTRICT and shall be accomplished in accordance with the details shown on the drawings. The encasement is a separate pay item.

## 8. SEEDING AND SODDING

Upon completion of the installation of the work, the CONTRACTOR shall remove all debris and surplus construction material resulting from the work. The CONTRACTOR shall fine grade all the disturbed surfaces around the area of the work in a uniform and neat manner leaving the construction area in a condition as near as possible to the original ground line or to the lines as directed by the DISTRICT.

All grade areas shall be left smooth and thickly sown with a mixture of grasses. The mixture of grasses shall consist of one-third (1/3) Rye grass, one-third (1/3) Kentucky Fescue and one-third (1/3) Kentucky Bluegrass by weight, and shall be applied to the graded areas at a rate of not less than 1 pound of seed per one thousand square feet of area. When the final grading has been completed, the entire graded area to be seeded shall be fertilized with 12-12-12 fertilizer, applied at the rate of 6 pounds per one thousand square feet of area. After the seed and fertilizer both have been applied, the CONTRACTOR shall then lightly cover the seed by use of a drag or other approved device. The seeded area shall then be covered with straw a depth of approximately 1 inch.

Where existing lawns have been disturbed, the existing sod will be removed and stored and replaced to its original position once the work is in place. If the CONTRACTOR damages or destroys the original sod, it shall be replaced with a sod having at least 60% good quality Kentucky Bluegrass, strongly rooted and free of pernicious weeds and shall be so laid that no voids occur between strips. When placing sod, it shall be tamped or rolled immediately after it is laid and the finished surface shall be true to grade, it is laid and the finished surface shall be true to grade, even and equally firm at all points. Well-screened topsoil shall be lightly sprinkled over the sodded areas and shall be raked to insure sealing the sod joints. The sodded areas shall be thoroughly watered. Sod damaged by the CONTRACTOR shall be replaced with new sod by the CONTRACTOR as no cost to the DISTRICT.

The fine grading, seeding, sodding and clean up shall be considered as incidental expense and shall not be separate pay items.

Meadows and hay fields will require replacement in kind unless the CONTRACTOR secures a release from the property OWNER agreeing to no replacement or alternate replacement.

## 9. PAVEMENT AND OTHER STRUCTURE REPLACEMENT

The CONTRACTOR shall replace all pavement cut or disturbed, with pavement similar in all respects to existing pavement in accordance with the Standard Details and at those locations approved by the DISTRICT. Every effort shall be made to avoid cutting the pavement. In restoring pavement, new pavement is required, except that granite paving blocks, sound brick or sound asphalt paving blocks may be reused. No permanent paving shall be placed within thirty (30)-days after the backfilling has been completed. All concrete and asphalt paving materials shall be in conformance with the Standard Details shown in the plans.

### 9.1 Classification of Pavements

A. Concrete Pavement Replacement - This pavement replacement shall be Portland cement concrete construction in accordance with the requirements shown in the Standard Details. It shall include all pavement replacement on concrete surfaced roads, concrete driveways, concrete sidewalks and concrete parking areas, both public and private.

B. Heavy-Duty Bituminous Pavement Replacement - This type of asphalt pavement replacement shall be bituminous concrete surface over concrete base in accordance with the details. This type of pavement replacement shall be used on all heavily trafficked roads having an existing pavement greater than 2", whether public or private, or in other locations as directed by the DISTRICT.

C. Light-Duty Bituminous Pavement Replacement - This type of pavement replacement shall be bituminous concrete constructed in accordance with the details. This item shall include all light-duty bituminous concrete roadways, bituminous driveways and bituminous parking lots, both public and private.

D. Crushed Stone Surface Replacement - This type of surface replacement shall include all graveled roadways, driveways, parking areas, or other gravel surfaced areas, both private and public. This type of surfacing may also be required as a base course for other pavement replacement.

9.2 Materials. The crushed stone backfill as noted on the drawings shall be dense graded aggregate per Kentucky Department of Highways Specifications. The CONTRACTOR shall continuously be responsible for the maintenance of the aggregate and the surface of the trenches until the pavement replacement is completed.

Portland cement concrete for pavement replacement shall contain a minimum of 6 gallons per sack of cement, the slump shall be between 2 and 4 inches, and the concrete shall have minimum 28-day compression strength of at least 3,500 PSI. Cement, aggregate and water shall be

described in these specifications for Class "A" concrete. A set of cylinders shall be made and tested for each 25 cubic yards of concrete placed, or fraction thereof, to supply representative sampling and testing of the concrete, upon the direction of the DISTRICT. The CONTRACTOR shall produce a broomed, or burlaped uniformly smooth and nonskid surface, consistent with the existing pavement.

Bituminous materials and mixes shall be consistent with the recommended practice of the asphalt institute and it shall conform to the requirements of the Kentucky Department of Highways for prime coat and Class 1 bituminous concrete. The bituminous concrete shall consist of a binder or base course and a surface course.

9.3 Installation of Pavement Replacement. The CONTRACTOR shall cut back the surfacing adjacent to the trench for 12 inches on both sides of the trench and shall cut down the dense graded aggregate he has placed to a depth required for either type of pavement replacement. The resulting surface shall be rolled to yield a smooth, dense surface and a uniform depth.

The concrete shall be placed in accordance with standard practice, with the welded wire mesh if required in proper position and thoroughly vibrated into place. The CONTRACTOR shall produce a surface consistent with the existing pavement. The CONTRACTOR shall apply a liquid curing component, sprayed on the surface of the concrete, and shall provide adequate protection to the pavement until it is set.

For bituminous concrete, the CONTRACTOR shall clean and broom the prepared surface, then apply the prime coat at the rate of 0.20 to 0.25 gallons per square yard, with a pressure distributor or approved pressure spray method. When the prime coat has become tacky by not dry and hard, the bituminous binder course, or base course, whichever applies, shall be placed and compacted. The CONTRACTOR shall then apply the surface course. It is recommended, but not required, that the base course remain in place for approximately one week before placing the surface course. The finished course shall be compacted and the completed surface shall match the grades and slopes of the adjacent existing surfacing and be free of offsets, depressions, raised places and all other irregular surfaces.

9.4 Seasonal and Weather Limitations for Pavement Replacement. In the event the progress and scheduling of the work is such that the bituminous pavement replacement would occur in the winter months, during adverse cold weather and/or during such times the asphalt plants are not in operation, then the final pavement replacement shall be postponed until favorable weather occurs in the spring and the asphalt plants resume normal operations. No bituminous concrete shall be laid when the temperature is below 40°F. except by written permission of the DISTRICT.

Concrete pavement shall not be placed when the temperature is such that the pavement placed will freeze before it has had adequate time to set and shall be placed in conformance with the temperature conditions specified in Section 3 of these specifications.

The CONTRACTOR shall be responsible for replacement of pavement which he has placed has been damaged by cold weather or freezing without additional compensation.

In the meantime, the CONTRACTOR will be required to maintain the temporary surfacing until the permanent pavement is placed. Such labor, materials and equipment as is required for temporary maintenance of the streets, roadways and driveways shall be provided at the CONTRACTOR'S expense and is not a pay item. The CONTRACTOR will be required to use a cold mix asphaltic concrete as a temporary surface for trenches under heavy traffic use.

9.5 Guarantee. The one-year guarantee as specified in the contract documents is also applicable to trench settlement and pavement replacement.

## 10. SIDEWALK REPLACEMENT

Sidewalks will be replaced if damaged by the CONTRACTOR in any way. Payment will be made for those sidewalks necessarily damaged by the line installation in accordance with the Standard Details. No sidewalks are to be replaced over a backfilled trench for at least 30 days after filling. Sidewalks damaged otherwise are to be replaced immediately at the CONTRACTOR'S expense.

Materials and dimensions are to be at least equal to existing walk and are to conform with the Standard Details.

## 11. PAYMENT FOR WATER

All water used from the UTILITY shall be metered with meters supplied by the CONTRACTOR. The CONTRACTOR shall pay for such water monthly at the rate of \$2.00/1,000 gallons. Unmetered water lost through water line breakage shall also be paid at the rate of \$2.00/1,000 gallons. The quality lost shall be computed on the basis of a discharge velocity of 7 feet/second, the diameter of the line, and the estimate duration of free uncontrolled discharge.

## 12. FINAL CLEAN-UP

The CONTRACTOR shall provide effective cleanup of the work as it progresses. Procrastination of cleanup will not be tolerated. At the time of final inspection, no trenches shall show any undue evidence of the previous construction. All areas shall be left free of ruts due to construction equipment and shall have a clean and neat appearance without rubble or debris. The areas shall not be mounded up and shall be completely restored, and all yards and fields shall be completely reseeded so land may be cultivated, mowed, etc. Straw and fertilizing shall accompany the seeding in accordance with Item 8 - Seeding and Sodding of this section. If necessary to hasten proper restoration of terraces, principally along ditch lines, the CONTRACTOR shall sod such areas at the DISTRICT'S direction. For all line segments, final cleanup shall be performed within 30 days from day of installation.



13. PROTECTION OF ADJACENT LANDSCAPE

Reasonable care shall be taken during construction of the water lines to avoid damage to vegetation. Ornamental shrubbery and tree branches shall be temporarily tied back, where appropriate, to minimize damage. Trees which receive damage to branches shall be trimmed of those branches to improve the appearance of the tree. Tree trunks receiving damage from equipment shall be treated with a tree dressing.

In the course of construction, the CONTRACTOR may deflect horizontal alignment of the water line to avoid trees and to keep from damaging their roots. The CONTRACTOR shall be fully responsible for settling all claims by private property owners concerning damage to trees and shrubs.

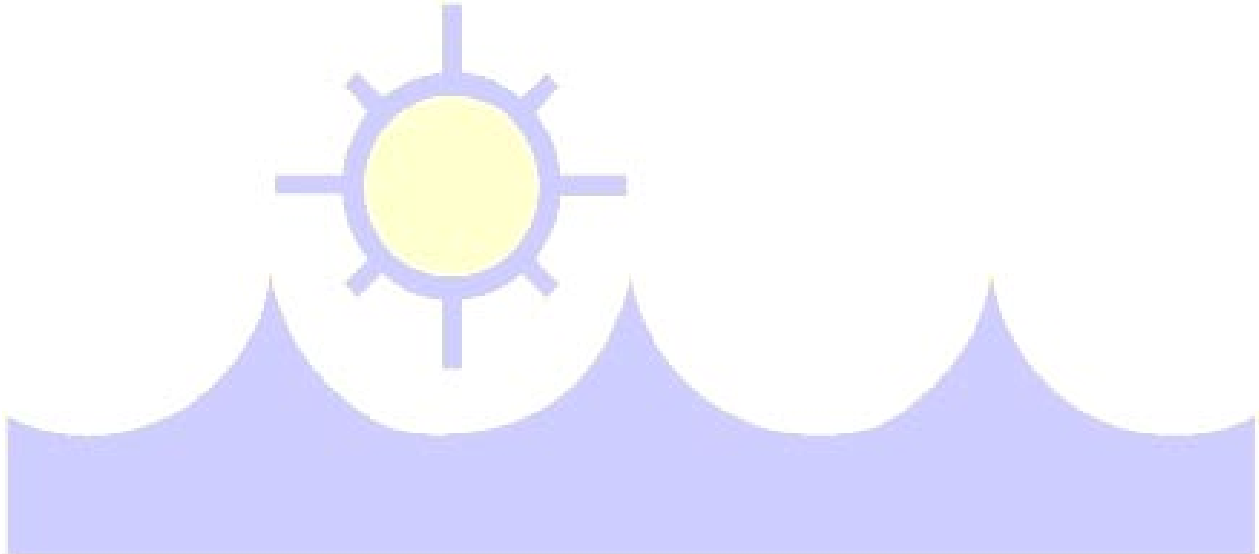

## GENERAL GUIDELINE FOR TESTING AND STERILIZATION

The following procedures are intended only as a general guideline. The order of the steps is very important and must not be deviated. All procedures must be completed with inspection by a representative from or designated person for Hardin County Water District No. 2

- Step 1. Filling new main with water: Provision for adding chlorine or chlorine compounds should be made at this time. Chlorine shall be added in sufficient to produce a free residual of not less than 50 parts per million. This 50-part solution must remain in contact with the new main for a minimum of 24 hours. At the end of the minimum 24 hour period, a residual of not less than 25 parts per million must be observed.
- Step 2. Flushing and dechlorination of all chlorinated water must be accomplished at this time by industry accepted practices.
- Step 3. New mains must be flushed sufficiently to expel any air, dirt, or foreign debris.
- Step 4. The appropriate number of bacteriological water samples must be collected from the new main in accordance with Kentucky regulations.
- Step 5. After clear or negative bacteriological water samples have been verified by an approved facility, then hydrostatic testing must be conducted. After completion of the successful hydrostatic test, new main can be put into service.

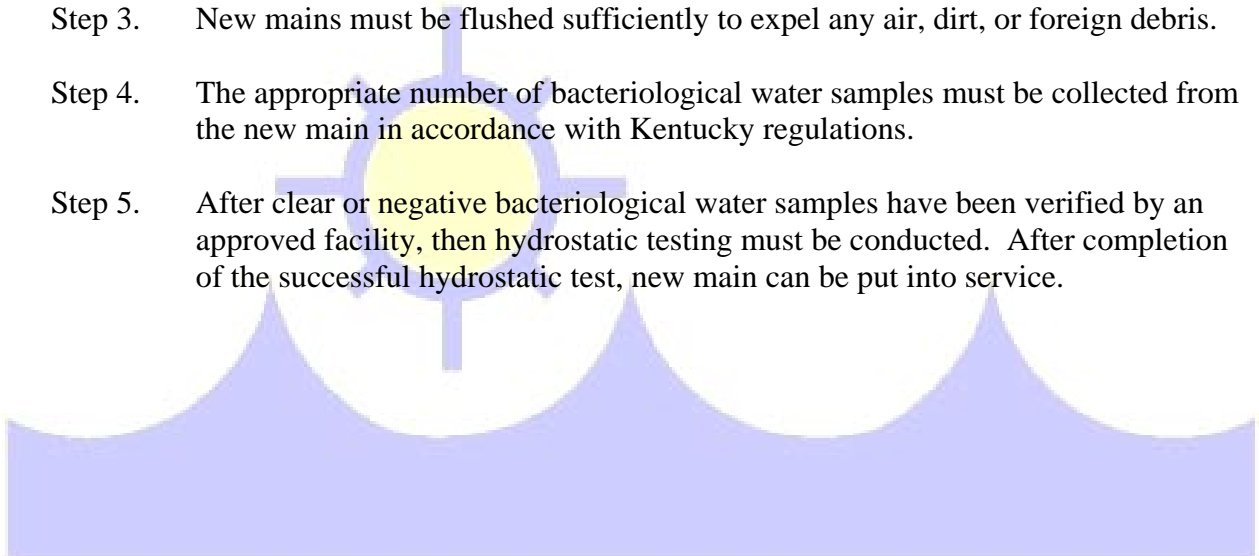

## TESTING AND STERILIZATION

### 1. TESTING

1.1 After the pipe has been laid, and after sterilization, dechlorination, flushing, and clear samples received, all newly laid pipe or any valved section thereof shall be subjected to a hydrostatic pressure test of at least 1.5 times the working pressure or a minimum of 150 psi at the point of testing, but in no case less than that required by other sections herein. In addition, a leakage test shall be conducted concurrently with the pressure test.

#### 1.2 Pressure Test

1.2.1 Test pressure shall:

1.2.1.1 Not be less than 1.25 times the working pressure at the highest point above the test section.

1.2.1.2 Not exceed pipe or thrust restraint design pressures at the lowest point along the test section.

1.2.1.3 Be of at least two (2) hour duration.

1.2.1.4 Not vary by more than plus or minus 5 psi.

1.2.1.5 Not to exceed twice the rated pressure of the valves or hydrants when the pressure of the test section includes closed gate valves or hydrants.

1.2.1.6 Not exceed the rated pressure of resilient seat butterfly valves when used.

1.2.2 Each Valved section of pipe shall be filled with water slowly and the specified test pressure, based on the elevation of the lowest point of the line or section under test and corrected to the elevation of the test gauge, shall be applied by means of a pump connected to the pipe in a manner satisfactory to the DISTRICT.

1.2.3 Before applying the specified test pressure, air shall be expelled completely from the pipe, valves, and hydrants. If permanent air vents are not located at all high points, the contractor shall install corporation cocks at such points so that the air can be expelled as the line is filled with water. After all the air has been expelled, the corporation cocks shall be closed and the test pressure applied. At the conclusion of the pressure test, the corporation cocks shall be removed and plugged, or left in place at the discretion of the DISTRICT.

1.2.4 All exposed pipe, fittings, valves, hydrants, and joints shall be examined carefully during the test. Any damage or defective pipe, fittings, valves or hydrants that are discovered following the pressure test shall be repaired or replaced with sound material and the test shall be repeated until it is satisfactory to the DISTRICT.

### 1.3 Leakage Testing

1.3.1 Leakage shall be defined as the quantity of water that must be supplied into the newly laid pipe, or any valved section thereof, to maintain pressure within 5 psi of the specified test pressure after the air in the pipeline has been expelled and the pipe has been filled with water.

1.3.2 No pipe installation will be accepted if the leakage is greater than that determined by the following formula:

$$L=ND(P \text{ exp } 1/2)/7400$$

in which L is the allowable leakage, in gallons per hour; N is the number of joints in the length of pipeline tested; D is the nominal diameter of the pipe, in inches; and P is the average test pressure during the leakage test, in pounds per square inch gauge.

1.3.2.1 Allowable leakage at various pressures is shown in TABLE K-1.

1.3.2.2 When testing against closed metal-seated valves, an additional leakage per closed valve of 0.0078 gal/hr/in of nominal valve size shall be allowed.

1.3.2.3 When hydrants are in the test section, the test shall be made against the closed hydrant.

1.3.3 Acceptance shall be determined on the basis of allowable leakage. If any test of pipe laid discloses leakage greater than that specified in Section 1.3.2 the contractor shall, at his own expense, locate and repair the defective material until the leakage is within the specified allowance.

1.3.3.1 All visible leaks are to be repaired regardless of the amount of leakage.

TABLE K-1  
ALLOWABLE LEAKAGE PER 1,000 FT. OF PIPELINE (gph)

Nominal Pipe Diameter (Inches)

Avg. Test Pressure psi	2	3	4	6	8	10	12	14	16
450	0.32	0.48	0.64	0.95	1.27	1.59	1.91	2.23	2.55
400	0.30	0.45	0.60	0.90	1.20	1.50	1.80	2.10	2.40
350	0.25	0.42	0.56	0.84	1.12	1.40	1.69	1.97	2.25
300	0.26	0.39	0.52	0.78	1.04	1.30	1.56	1.82	2.08
275	0.25	0.37	0.50	0.75	1.00	1.24	1.49	1.74	1.99
250	0.24	0.36	0.47	0.71	0.95	1.19	1.42	1.66	1.90
225	0.23	0.34	0.45	0.68	0.90	1.13	1.35	1.58	1.80
200	0.21	0.32	0.43	0.64	0.85	1.06	1.28	1.48	1.70
175	0.20	0.30	0.40	0.59	0.80	0.99	1.19	1.39	1.59
150	0.19	0.28	0.37	0.55	0.74	0.92	1.10	1.29	1.47
125	0.17	0.25	0.34	0.50	0.67	0.84	1.01	1.18	1.34
100	0.15	0.23	0.30	0.45	0.60	0.75	0.90	1.05	1.20

Nominal Pipe Diameter (Inches)

Avg. Test Pressure psi	18	20	24	30	36	42	48	54
450	2.87	3.18	3.82	4.78	5.73	6.69	7.64	8.60
400	2.70	3.00	3.60	4.50	5.41	6.31	7.21	8.11
350	2.53	2.81	3.37	4.21	5.06	5.90	6.74	7.58
300	2.34	2.60	3.12	3.90	4.68	5.46	6.24	7.02
275	2.24	2.49	2.99	3.73	4.48	5.23	5.98	6.72
250	2.14	2.37	2.85	3.56	4.27	4.99	5.70	6.41
225	2.03	2.35	2.70	3.38	4.05	4.73	5.41	6.03
200	1.91	2.12	2.55	3.19	3.82	4.46	5.09	5.73
175	1.79	1.98	2.38	2.98	3.58	4.17	4.77	5.36
150	1.66	1.84	2.21	2.76	3.31	3.86	4.41	4.97
125	1.51	1.68	2.01	2.52	3.02	3.53	4.03	4.53
100	1.35	1.50	1.80	2.25	2.70	3.15	3.60	4.05

## 2. STERILIZATION

2.1 General. It is the intent of this section to present essential procedures for disinfecting new and repaired water mains. The section is patterned after AWWA C651-92. The basic procedure comprises:

2.1.1 Preventing contaminating materials from entering the water mains during construction or repair and removing by flushing materials that may have entered the water main.

2.1.2 Disinfecting any residual contamination that may remain.

2.1.3 Determining the bacteriologic quality by laboratory test after disinfection.

### 2.2 Preventive Measures During Construction

2.2.1 Precautions shall be taken to protect pipe interiors, fittings, and valves against contamination. Pipe delivered for construction shall be strung so as to minimize entrance of foreign material. When pipe laying is not in progress, as, for example, at the close of the day's work, all openings in the pipeline shall be closed by watertight plugs. Joints of all pipe in the trench shall be completed before work is stopped. If water accumulates in the trench, the plugs shall remain in place until the trench is dry.

If dirt, that, in the opinion of the DISTRICT, will not be removed by the flushing operation (ARTICLE 2.3) enters the pipe, the interior of the pipe shall be cleaned and swabbed as necessary, within five (5%) percent hypochlorite disinfecting solution.

2.2.2 Packing Materials and Joints - No contaminate material or may material capable of supporting prolific growth of micro-organisms shall be used for sealing joints. Packing material shall be handled in such a manner as to avoid contamination. Where applicable, packing materials must conform to AWWA standards. Packing material for cast iron pipe must conform to AWWA C600. Yarning or packing material shall consist of molded or tubular rubber rings, rope of asbestos or treated paper. Material such as jute or hemp shall not be used. The lubricant used in the installations of sealing gaskets shall be suitable for use in potable water. It shall be delivered to the job in enclosed containers and shall be kept clean.

2.3 Preliminary Flushing. The main shall be flushed prior to disinfection, except when the tablet method is used (ARTICLE 2.5.3). It is recommended that the flushing velocity be not less than 2.5 ft/sec. The rate of flow required to produce this velocity in various diameters is shown in Table K-2. No site for flushing should be chosen unless it has been determined that drainage is adequate at the site.

TABLE K-2  
 REQUIRED OPENINGS TO FLUSH PIPELINES  
 (40-psi Residual Pressure)

Pipe Size (In)	Flow Required to Produce 2.5 fps Velocity (gpm)	Orifice Size (in)	Number	Size (in)
4	100	15/16	1	2 ½
6	220	1 3/8	1	2 ½
8	390	1 7/8	1	2 ½
10	610	2 5/16	1	2 1/2
12	880	2 13/16	1	2 1/2
14	1,200	3 1/4	2	2 1/2
16	1,565	3 5/8	2	2 1/2
18	1,980	4 3/16	2	2 1/2

**2.4 Form of Chlorine for Disinfection.** The most common forms of chlorine used in the disinfecting solutions are liquid chlorine (gas at atmospheric pressure), calcium hypochlorite granules, and sodium hypochlorite solutions.

**2.4.1 Use:** Liquid chlorine shall be used only when suitable equipment is available and only under the direct supervision of a person familiar with the physiological, chemical, and physical properties of this element and who is properly trained and equipped to handle any emergency that may arise. Introduction of chlorine-gas directly from the supply cylinder is unsafe and shall not be permitted.

**NOTE:** The preferred equipment consists of a solution fed chlorinator in combination with a booster pump for injecting the chlorine-gas water mixture into the main to be disinfected. Direct feed chlorinators are not recommended because their use is limited to situations where the water pressure is lower than the chlorine cylinder pressure.



## 2.4.2 Hypochlorites

2.4.2.1 Calcium Hypochlorite: Calcium hypochlorite contains seventy (70%) percent available chlorine by weight. It is either granular or tabular in form. The tablets, 6-8 to the ounce, are designed to dissolve slowly in water. Calcium hypochlorite is packaged in containers of various types and sizes ranging from small plastic bottles to one hundred (10) pound drums.

A chlorine-water solution is prepared by dissolving the granules in water in the proportion requisite for the desired concentration.

2.4.2.2 Sodium Hypochlorite: Sodium hypochlorite is supplied in strengths from five and one-quarter (5.25%) to sixteen (16%) percent available chlorine. It is packaged in liquid form in glass, rubber, or plastic containers ranging in size from one (1) quart bottles to five (5) gallon carboys. It may also be purchased in bulk for delivery by tank trucks.

The chlorine-water solution is prepared by adding hypochlorite to water. Product deterioration must be reckoned with in computing the quantity of sodium hypochlorite required for the desired concentration.

2.4.2.3 Application: The hypochlorite solutions shall be applied to the water main with a gasoline or electrically powered chemical feed pump designed for feeding chlorine solutions. For small applicants, the solutions may be fed with a hand pump, for example, a hydraulic test pump. Feed lines shall be of such material and strength as to withstand safely the maximum pressures that may be created by the pumps. All connections shall be checked for tightness before the hypochlorite solution is applied to the main.

## 2.5 Methods of Chlorine Application

2.5.1 Continuous Feed Method: This method is suitable for general application.

2.5.1.1 Water from the existing distribution system or other approved sources of supply shall be made to flow at a constant, measured rate into the newly laid pipeline. The water shall receive a dose of chlorine, also fed at a constant measured rate. The two rates shall be proportioned so that the chlorine concentration in the water in the pipe is maintained at a minimum of 50 mg/l available chlorine residual should be measured at regular intervals in accordance with the procedures described in the current edition of Standard Methods and AWWA M12--Simplified Procedures for Water Examination.

NOTE: In the absence of a meter, the rate may be determined either by placing a pitot gauge at the discharge or by measuring the time to fill a container of known volume.

TABLE K-3 gives the amount of chlorine residual required for each one hundred (100) feet of pipe of various diameters. Solutions of one (1%) percent chlorine may be prepared with sodium hypochlorite or calcium hypochlorite. The latter solution requires approximately one (1) pound of calcium hypochlorite in eight and five tenths (8.5) gallons of water.

TABLE K-3  
 CHLORINE REQUIRED TO PRODUCE 50 Mg/1 CONCENTRATION  
 IN 100 FT. OF PIPE (BY DIAMETER)

Pipe Size (in)	100 Percent Chlorine (lb)	1 Percent Chlorine Solutions (gal)
4	0.027	0.33
6	0.061	0.73
8	0.108	1.30
10	0.170	2.04
12	0.240	2.88

2.5.1.2 During the application of the chlorine, valves shall be manipulated to prevent the treatment dosage from flowing back into the line supplying water. Chlorine application shall not cease until the entire main is filled with the chlorine solution. The chlorinated water shall be retained in the main for at least twenty-four (24) hours during which time all valves and hydrants in the section treated shall be operated in order to disinfect the appurtenances. At the end of this twenty-four (24) hour period, the treated water shall contain no less than 25 mg/1 chlorine throughout the length of the main.

2.5.2 **Slug Method:** This method is suitable for use with mains of large diameter for which, because of the volumes of water involved, the continuous feed method is not practical.

2.5.2.1 Water from the existing distribution system or other approved source of supply shall be made to flow at a constant, measured rate (see ARTICLE 2.5.1.1) into the newly laid pipeline. The water shall receive a dose of chlorine also fed at a constant, measured rate. The flow rates shall be proportioned so that the concentration of the water entering the pipeline is maintained at no less than 300 mg/1. The chlorine shall be applied continuously and for a sufficient period to develop a solid column or “slug” of chlorinated water that will, as it passes along the line, expose all interior surfaces to a concentration of at least 300 mg/1 for at least three (3) hours. The application shall be checked at a tap near the upstream end of the line by chlorine residual measurements.

2.5.2.2 As the chlorinated water flows past tees and crosses, related valves and hydrants shall be operated as to disinfect appurtenances.

2.5.3 **Tablet Method.** The tablet method consists of placing calcium hypochlorite granules or tablets in the water main as it is being installed and then filling the main with potable water when installation is completed.

This method may be used only if the pipes and appurtenances are kept clean and dry during construction and are filled and placed in service within a two-week period. This method shall be approved by the DISTRICT prior to its use. The use of this method may be terminated, if in the opinion of the DISTRICT, the conditions of approval are violated.

Specific procedures for this method may be found in ANSI/AWWA C651-92, Section 5.1.

## 2.6 Final Flushing.

2.6.1 Clearing the Main of Heavily Chlorinated Water. After the applicable retention period, the heavily chlorinated water shall not remain in prolonged contact with the pipe. This water shall be flushed from the main until the chlorine concentration in the water leaving the main is no higher than that prevailing in the system, or less than 1 mg/l. Chlorine residuals determination shall be made to ascertain that the heavily chlorinated water has been removed from the pipeline.

2.6.2 Disposing of Heavily Chlorinated Water. The environment into which the chlorinated water is to be discharged shall be inspected. A neutralizing chemical shall be applied to the water to be wasted to neutralize thoroughly the chlorine residual remaining in the water. (See Appendix B of ANSI/AWWA C651-92 for neutralizing chemicals.) Federal, state, provincial, and local regulatory agencies should be contacted to determine special provisions for the disposal of heavily chlorinated water.

## 2.7 Bacteriologic Tests

2.7.1 After line flushing, and before the water main is placed in service, a sample or samples shall be collected from the end of the line and tested for bacteriologic quality and shall show the absence of coliform organisms. If the number and frequency of samples is not prescribed by the public health authority having jurisdiction, at least one sample shall be collected from chlorinated supplies where a chlorine residual is maintained throughout the new main. From unchlorinated supplies at least two samples shall be collected at least twenty-four (24) hours apart.

2.7.2 Samples for bacteriologic analysis shall be collected in sterile bottles treated with sodium thiosulfate. No hose or fire hydrant shall be used in collection of samples. A suggested sampling tap consists of a standard corporation cock installed in the main with a copper tube gooseneck assembly. After samples have been collected, the gooseneck assembly may be removed, and retained for future use.

2.8 Repetition of Procedure. If the initial disinfection fails to produce satisfactory samples, disinfection shall be repeated until satisfactory samples have been obtained. The tablet method cannot be used in these subsequent disinfection.

2.9 Procedure After Cutting Into or Repairing Existing Mains. The procedures outlined in this Article apply primarily when mains are wholly or partially dewatered. Leaks or breaks that are repaired with clamping devices while the mains remain full of water under pressure present little danger of contamination and require no disinfection.

2.9.1 Trench “Treatment”: When an old line is opened, either by accident or by design, the excavation will likely be wet and may be badly contaminate from nearby sewers. Liberal quantities of hypochlorite applied to open trench areas will lessen the danger from such pollution. Tablets have the advantage in such a situation because they dissolve slowly and continue to release hypochlorite as water is pumped from the excavation.

2.9.2 Main Disinfection: The following procedure is considered as a minimum that may be used.

2.9.2.1 Swabbing With Hypochlorite Solution: The interior of all pipe and fittings used in making the repair (particularly couplings and tapping sleeves) shall be swabbed with a five (5%) percent hypochlorite solution before they are installed.

2.9.2.2 Flushing: Through flushing is the most practical means of removing contamination introduced during repairs. If valving and hydrant locations permit, flushing from both directions is recommended. Flushing shall be started as soon as the repairs are completed and continued until discolored water is eliminated.

2.9.2.3 Slug Method: Where practicable, in addition to the procedures ARTICLE 2.9.2.1, a section of main in which the break is located shall be isolated, all service connections shut off, and the section flushed and chlorinated as described in ARTICLE 2.5.2, except that the dose may be increased to as much as 500 mg/l, and the contact time reduced to as little as one-half (1/2) hour. After chlorination, flushing shall be resumed and continued until discolored water is eliminated.

2.9.3 Sampling: Bacteriologic samples shall be taken after repairs to provide a record by which the effectiveness of the procedures used can be determined. If the direction of flow is unknown, samples shall be taken on each side of the main break.

# **IV. STANDARD DRAWINGS AND DETAILS**

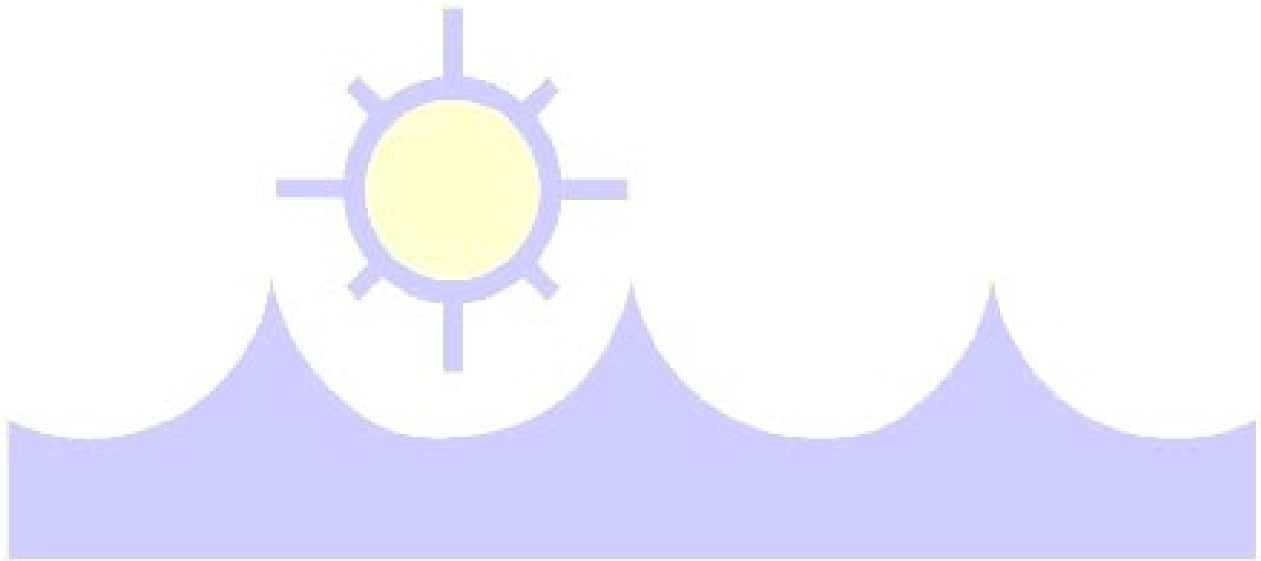

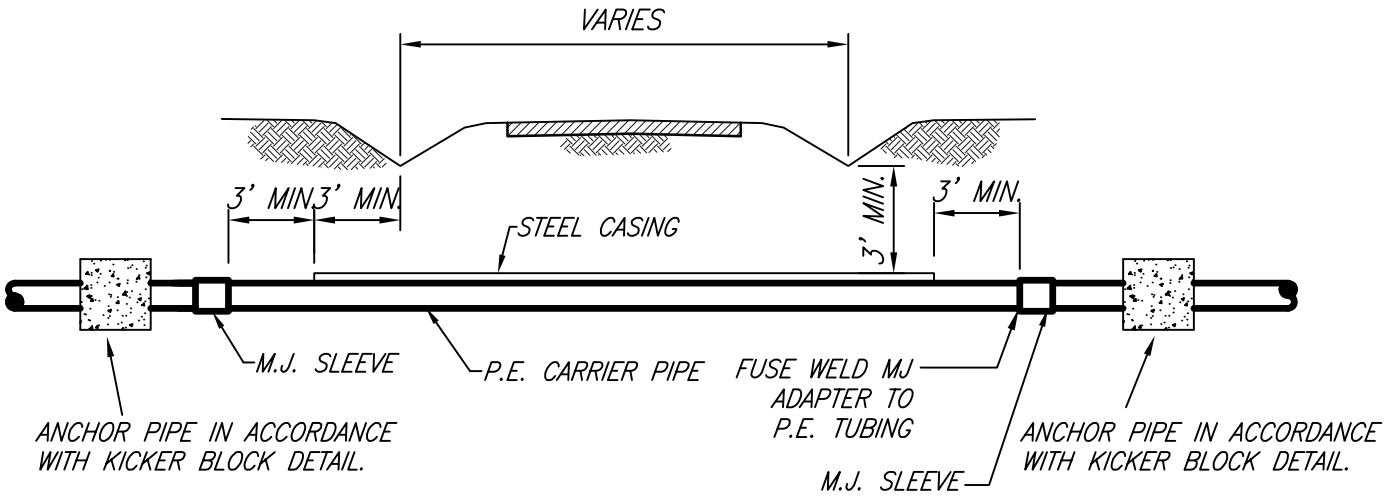

**BORE DETAIL W/ KICKER BLOCKS**

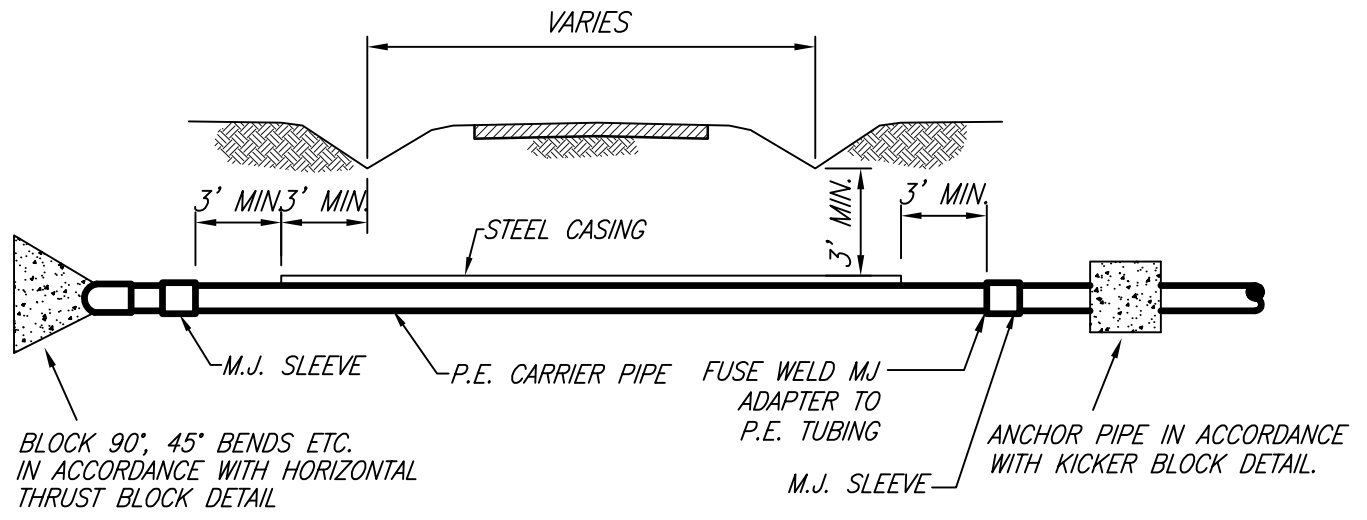

**BORE DETAIL W/ THRUST BLOCK & KICKER BLOCK**

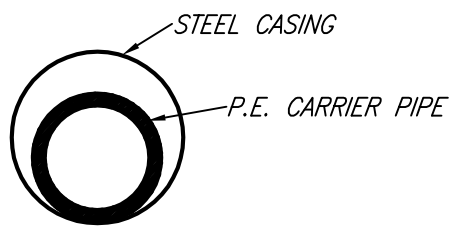
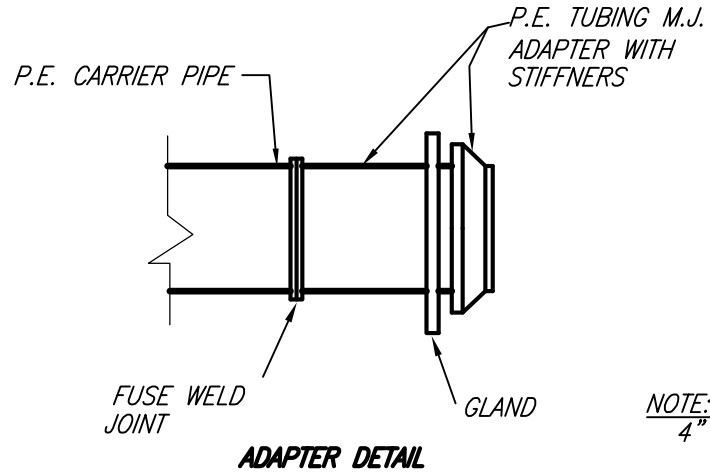

NOTE: STEEL CASING DIAMETER SHALL BE AT LEAST 4" LARGER THAN CARRIER PIPE.

NO.	REVISION	DATE	APPR. BY

**HIGHWAY / RAILROAD**  
**BORE DETAIL**

SCALE: NOT TO SCALE  
DATE: 8/31/07  
APPROVED BY: JJ

**HARDIN COUNTY WATER DISTRICT #2**

360 RING ROAD  
P.O. BOX 970  
ELIZABETHTOWN, KY 42702  
PH. (270) 737-1056

62

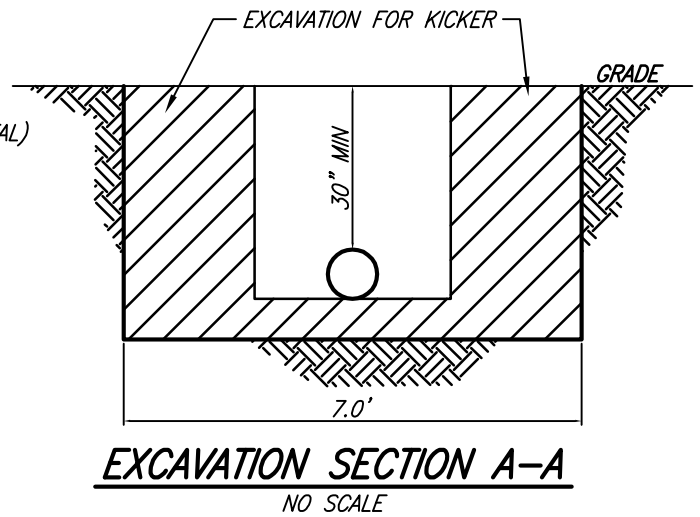
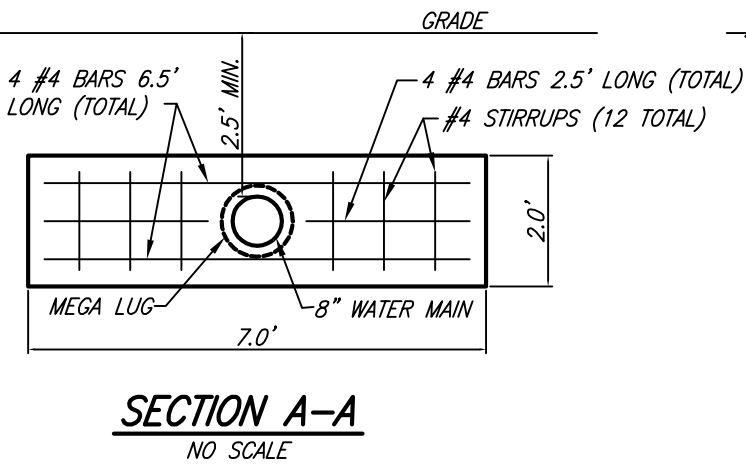
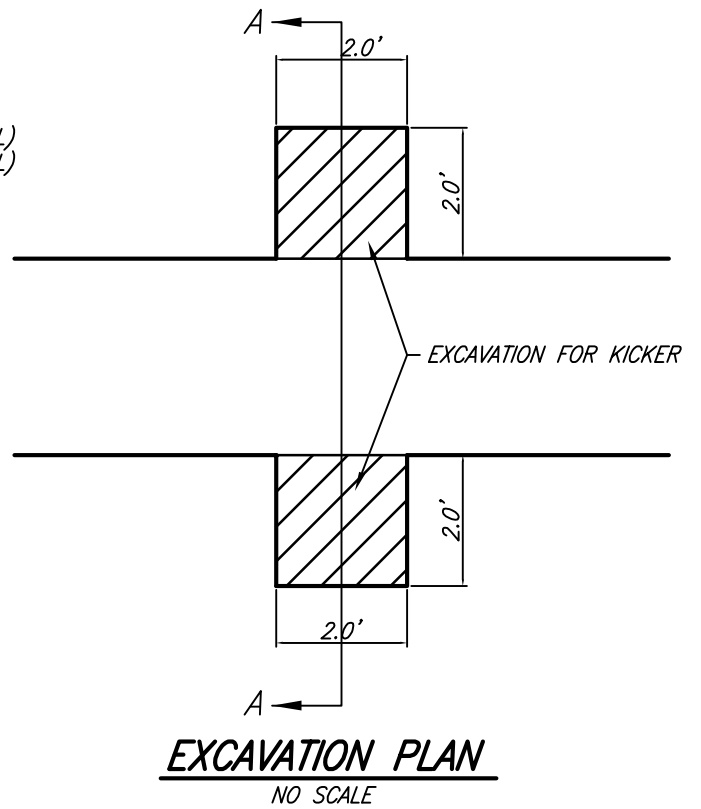
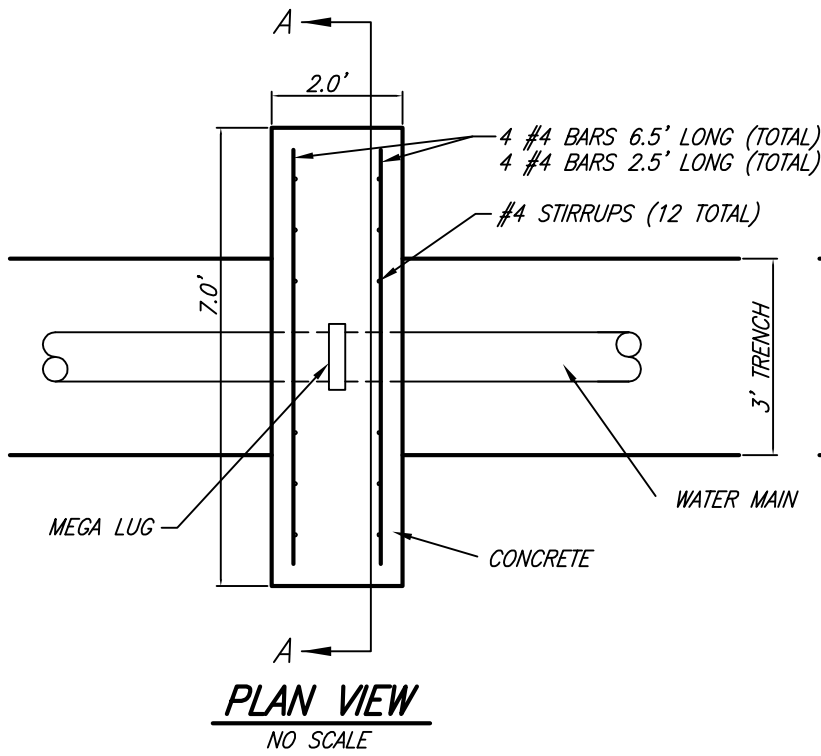

NOTE: EXCAVATION FOR THE KICKER SHOULD BE VERTICAL SIDE WALLS INTO UNDISTURBED SOIL.

NO.	REVISION	DATE	APPR. BY

**KICKER BLOCK  
DETAIL**

SCALE: NOT TO SCALE  
DATE: 8/31/07  
APPROVED BY: JJ



**HARDIN COUNTY WATER  
DISTRICT #2**

360 RING ROAD  
P.O. BOX 970  
ELIZABETHTOWN, KY 42702-0066  
(270) 737-1056







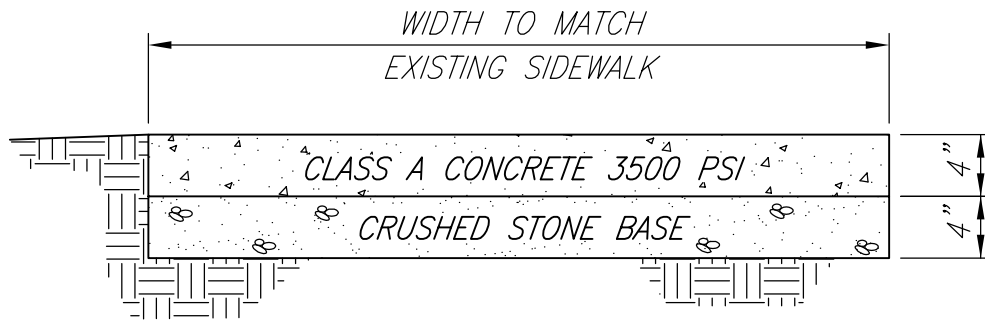

NO.	REVISION	DATE	APPR. BY

**CONCRETE SIDEWALK  
REPLACEMENT**

SCALE: NOT TO SCALE  
 DATE: 8/31/07  
 APPROVED BY: JJ



**HARDIN COUNTY WATER  
DISTRICT #2**

360 RING ROAD  
 P.O. BOX 970  
 ELIZABETHTOWN, KY 42702  
 (270) 737-1056

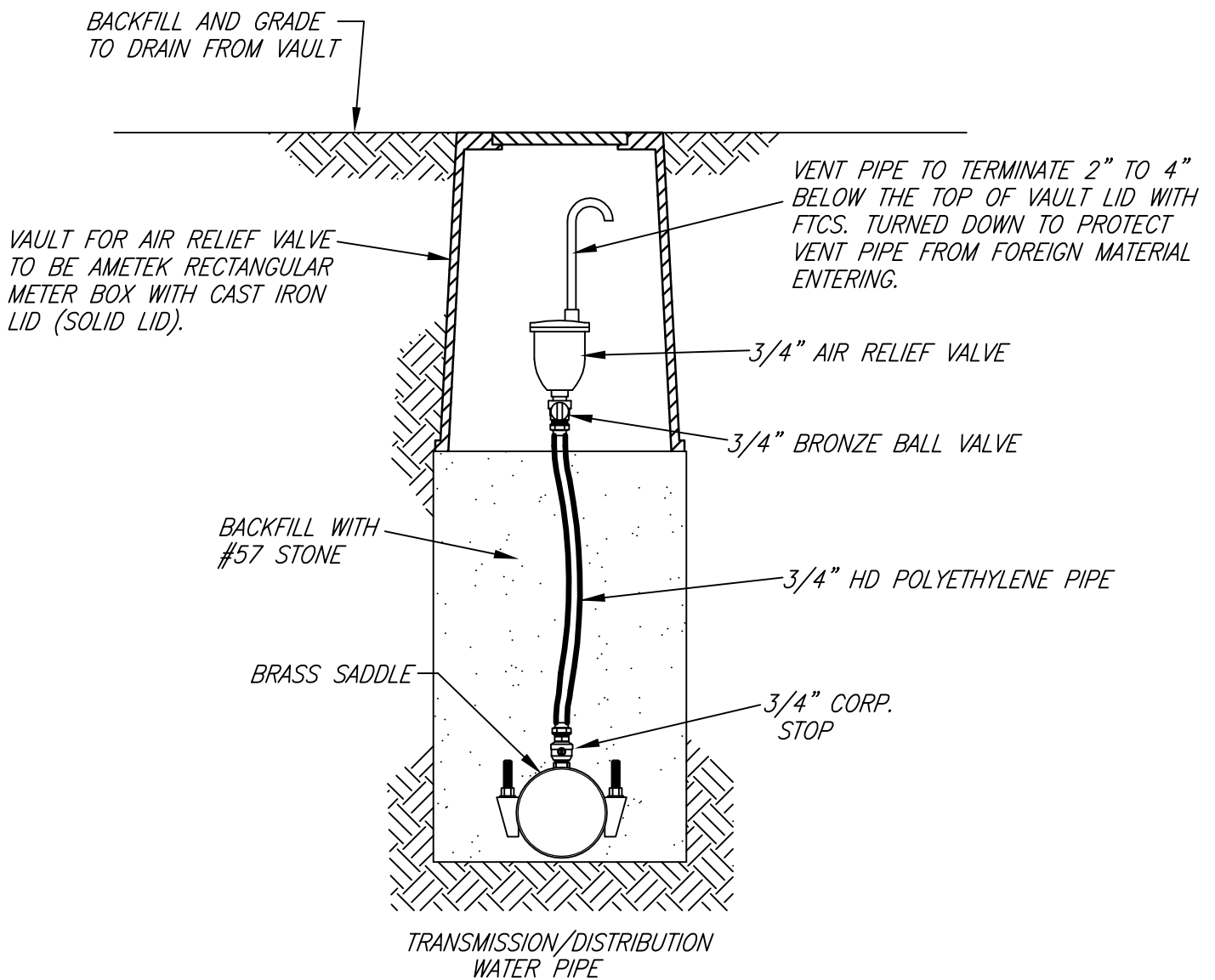

NO.	REVISION	DATE	APPR. BY

**3/4" AIR RELIEF VALVE DETAIL**

SCALE: NOT TO SCALE  
 DATE: 8/31/07  
 APPROVED BY: JJ



**HARDIN COUNTY WATER DISTRICT #2**

360 RING ROAD  
 P.O. BOX 970  
 ELIZABETHTOWN, KY 42702  
 PH. (270) 737-1056





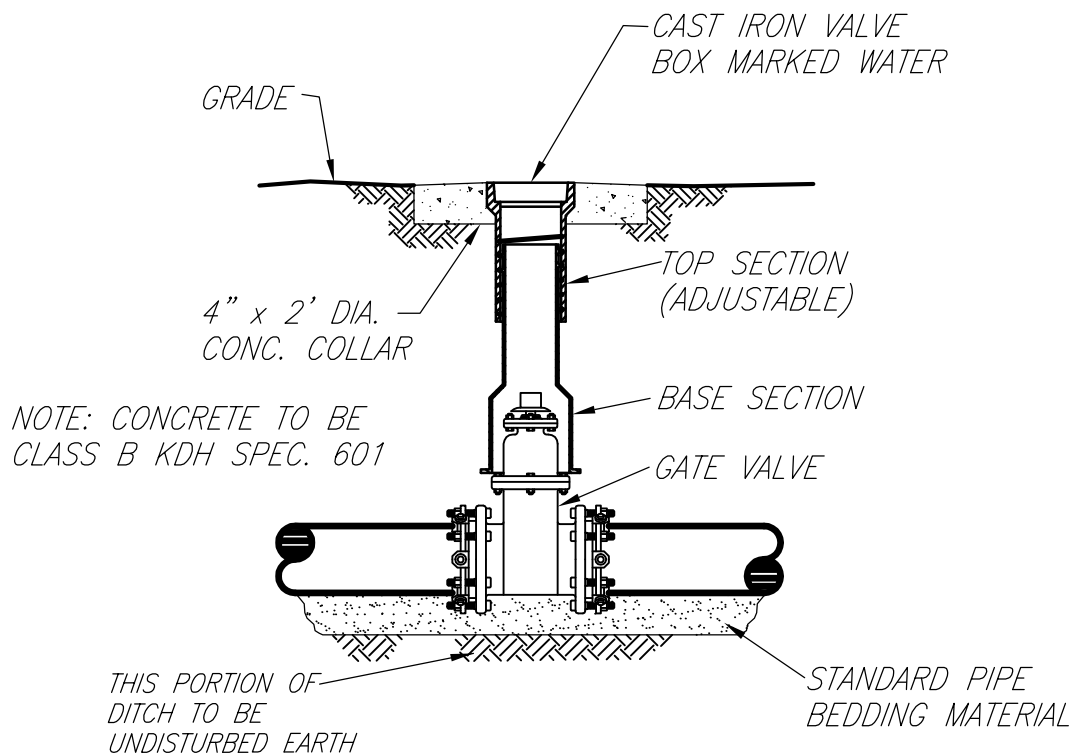

NOTE: SEE SPECIFICATIONS FOR PIPING MATERIALS AND PIPING JOINTS.

**C.I. VALVE BOX  
DETAIL**



**HARDIN COUNTY WATER  
DISTRICT #2**

360 RING ROAD  
P.O. BOX 970  
ELIZABETHTOWN, KY 42702  
(270) 737-1056

SCALE: NOT TO SCALE  
DATE: 8/31/07  
APPROVED BY: JJ

NO.	REVISION	DATE	APPR. BY

ALL MECHANICAL JOINT FITTINGS WHERE THRUST BLOCKING IS REQUIRED WILL ALSO BE SECURED BY "MEGA LUG" JOINT RESTRAINT GLANDS.

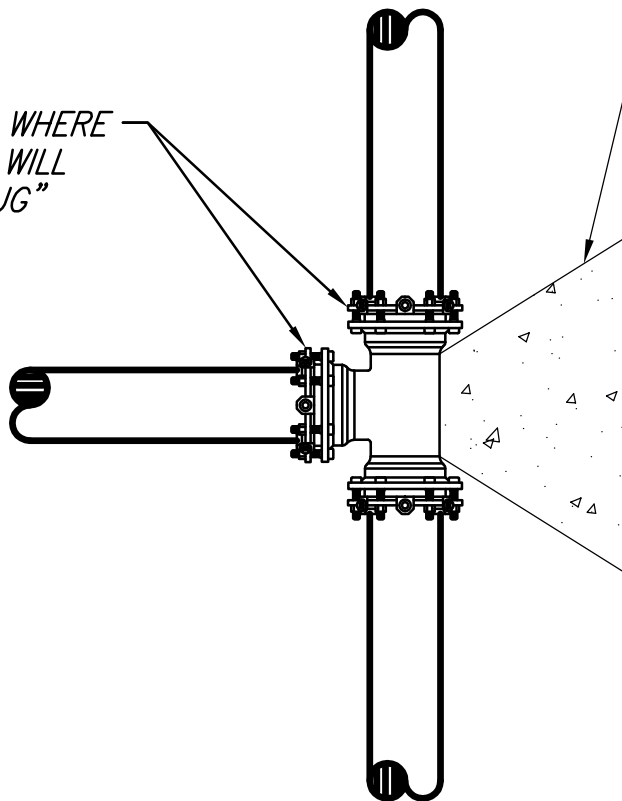

THRUST BLOCK  
(SEE HORIZONTAL  
THRUST BLOCK  
DETAIL).

NO.	REVISION	DATE	APPR. BY

**MECH. JOINT FITTING  
RESTRAINT DETAIL**

SCALE: NOT TO SCALE  
DATE: 8/31/07  
APPROVED BY: JJ



**HARDIN COUNTY WATER  
DISTRICT #2**

360 RING ROAD  
P.O. BOX 970  
ELIZABETHTOWN, KY 42702  
(270) 737-1056

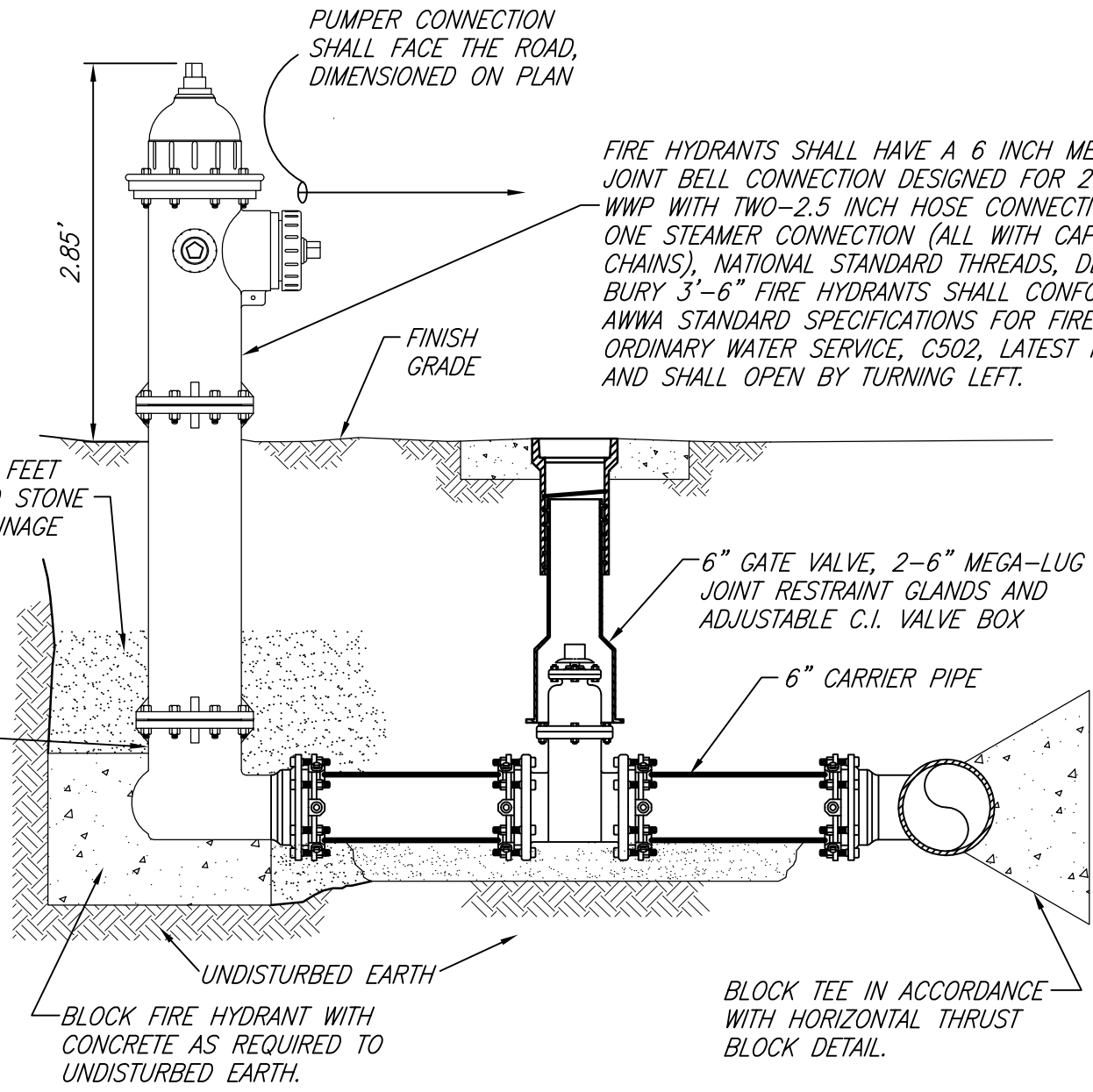

FIRE HYDRANTS SHALL HAVE A 6 INCH MECHANICAL JOINT BELL CONNECTION DESIGNED FOR 200 POUNDS WWP WITH TWO-2.5 INCH HOSE CONNECTIONS AND ONE STEAMER CONNECTION (ALL WITH CAPS AND CHAINS), NATIONAL STANDARD THREADS, DEPTH OF BURY 3'-6" FIRE HYDRANTS SHALL CONFORM TO AWWA STANDARD SPECIFICATIONS FOR FIRE HYDRANTS ORDINARY WATER SERVICE, C502, LATEST REVISION, AND SHALL OPEN BY TURNING LEFT.

NOTE: ALL MECHANICAL JOINT FITTINGS ARE TO BE ASSEMBLED WITH "MEGA-LUG" JOINT RESTRAINT GLANDS.

NO.	REVISION	DATE	APPR. BY

**FIRE HYDRANT SETTING DETAIL**

SCALE: NOT TO SCALE  
 DATE: 8/31/07  
 APPROVED BY: JJ



**HARDIN COUNTY WATER DISTRICT #2**

360 RING ROAD  
 P.O. BOX 970  
 ELIZABETHTOWN, KY 42702  
 (270) 737-1056









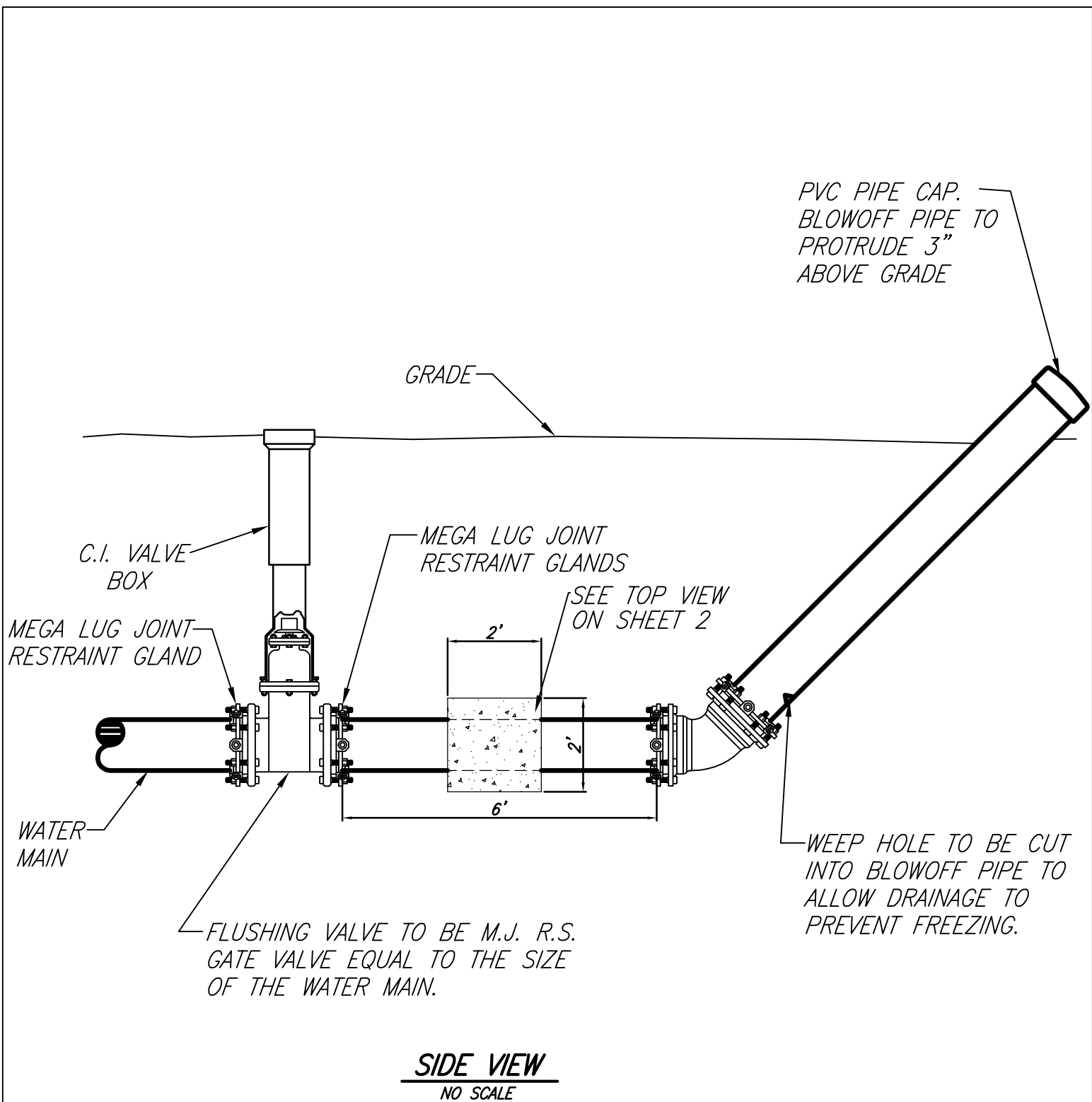

NO.	REVISION	DATE	APPR. BY

**TYPE 2 BLOWOFF**  
**ASSEMBLY DETAIL**  
**SHEET 1 OF 2**

SCALE: NOT TO SCALE  
DATE: 8/31/07  
APPROVED BY: JJ



**HARDIN COUNTY WATER DISTRICT #2**

360 RING ROAD  
P.O. BOX 970  
ELIZABETHTOWN, KY 42702-0066  
PH. (270) 737-1056 <sup>76</sup>

























